

SANCTION TEXT

APPROVING AUTHORITY DIGITAL SIGNATURE

DOOR & WINDOW SCHEDULE

SL. NO.	TYPE	SIZE	DESCRIPTION
1	D	1.20 X 2.10	PANELLED DOOR
2	D1	1.00 X 2.10	PANELLED DOOR
3	D2	0.90 X 2.10	PANELLED DOOR
4	W1	1.95 X 1.20	MS. GLAZED WINDOW
5	W2	2.00 X 1.20	MS. GLAZED WINDOW
6	W3	1.25 X 1.20	MS. GLAZED WINDOW
7	V	0.60 X 0.60	MS. GLAZED VENTILATOR

AREA AND BUILDING PARAMETERS

PLOT DIMENSIONS (IN FEET)	40' X 60'
PLOT DIMENSIONS (IN MT)	12.19M X 18.28M
PLOT AREA	222.83 SQMT
GROUND FLOOR BUILT UP AREA	108.00 SQMT
FIRST FLOOR BUILT UP AREA	85.52 SQMT
TOTAL BUILT UP AREA	193.52 SQMT
FLOOR AREA RATIO (FAR)	0.86
BUILDING HEIGHT	6.60 MT
PLANTATION AREA	
NUMBER OF TREES PROVIDED	2 NOS.

APPLICANT DETAILS

NAME OF APPLICANT	
ADDRESS	
CONTACT NUMBER	

LAND DETAILS

REVENUE VILLAGE	
REVENUE PLOT NO	
SCHEME PLOT NO/ LAYOUT	
PLOT NO/ SUB PLOT NO	
KHATA NUMBER	

SITE PLAN

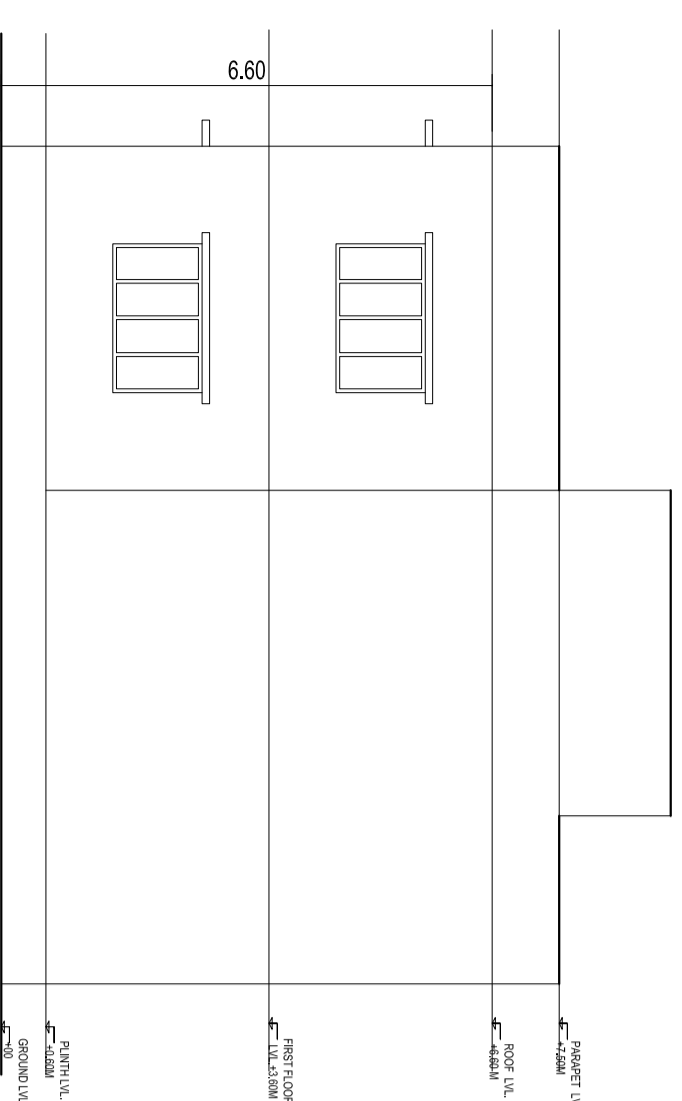
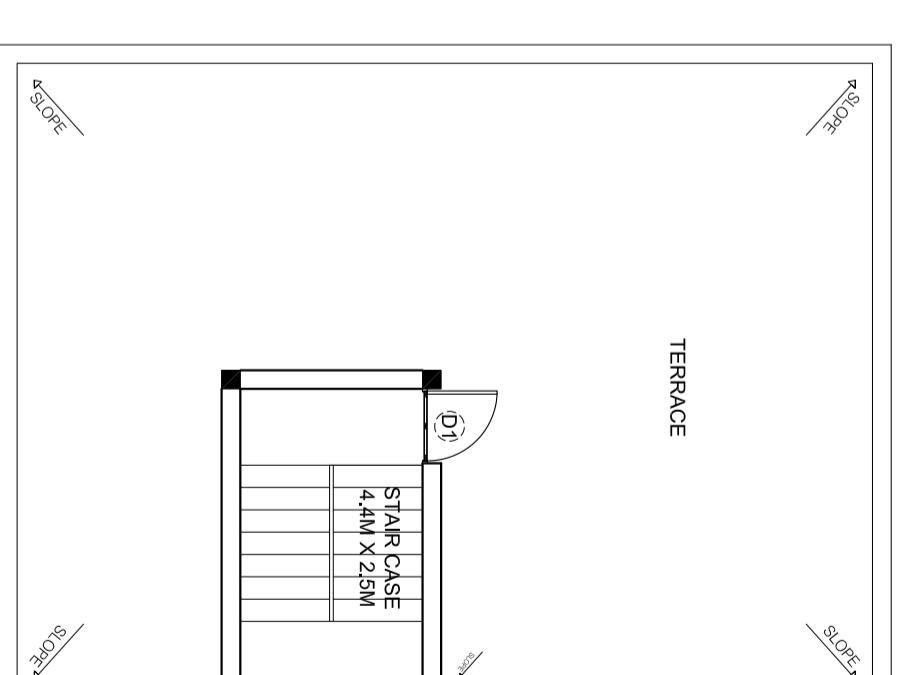

FRONT ELEVATION

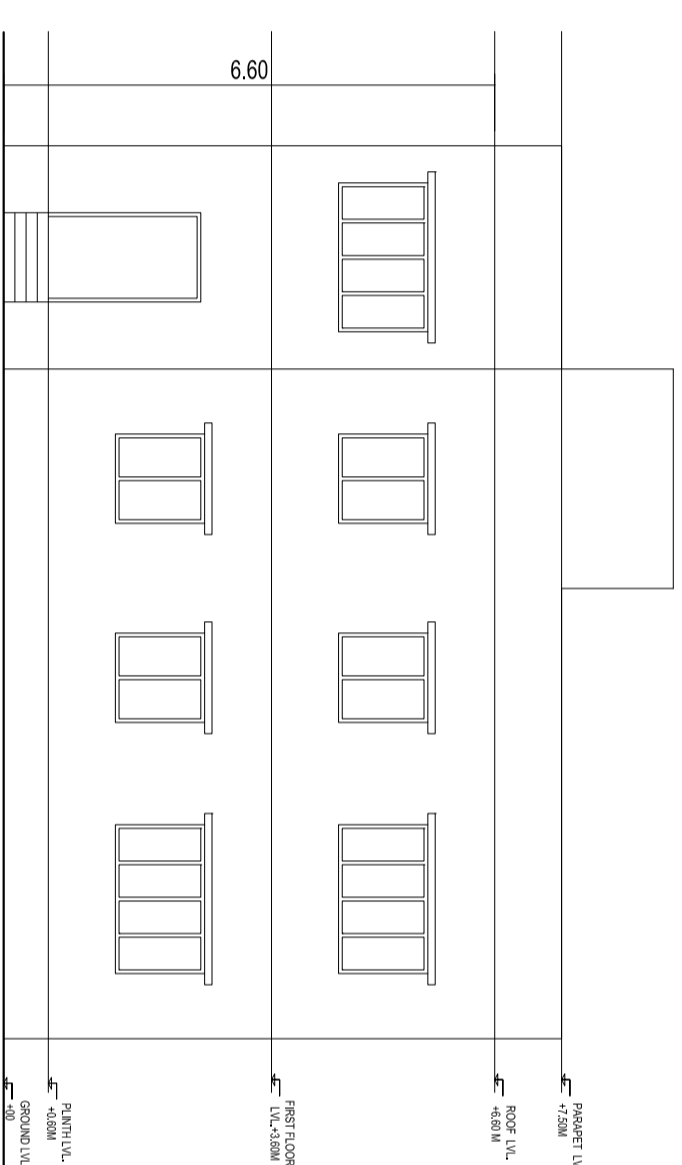

LEFT ELEVATION

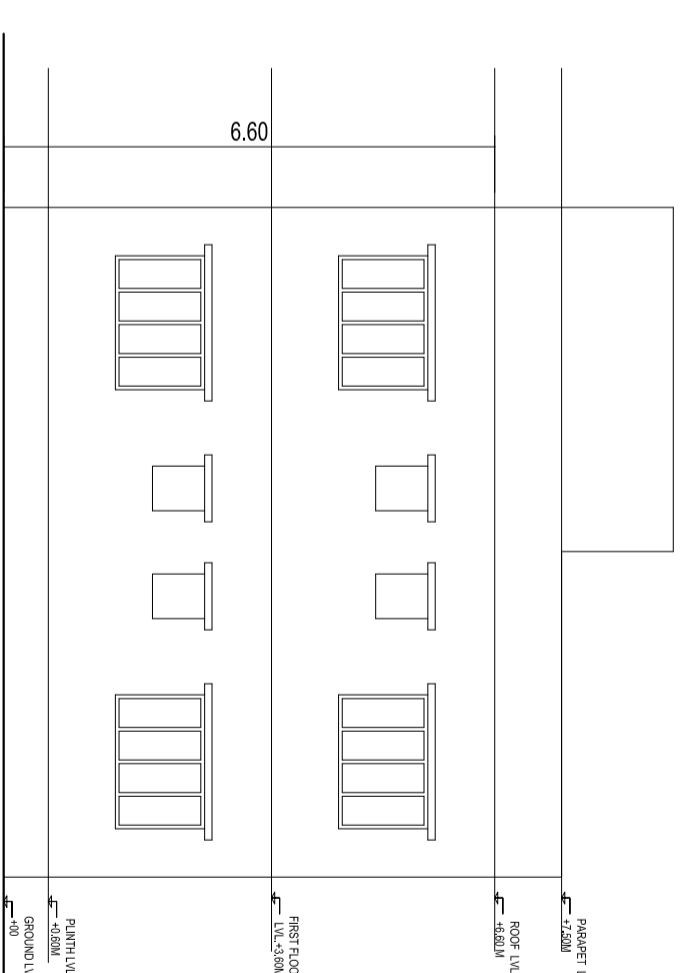

RIGHT ELEVATION

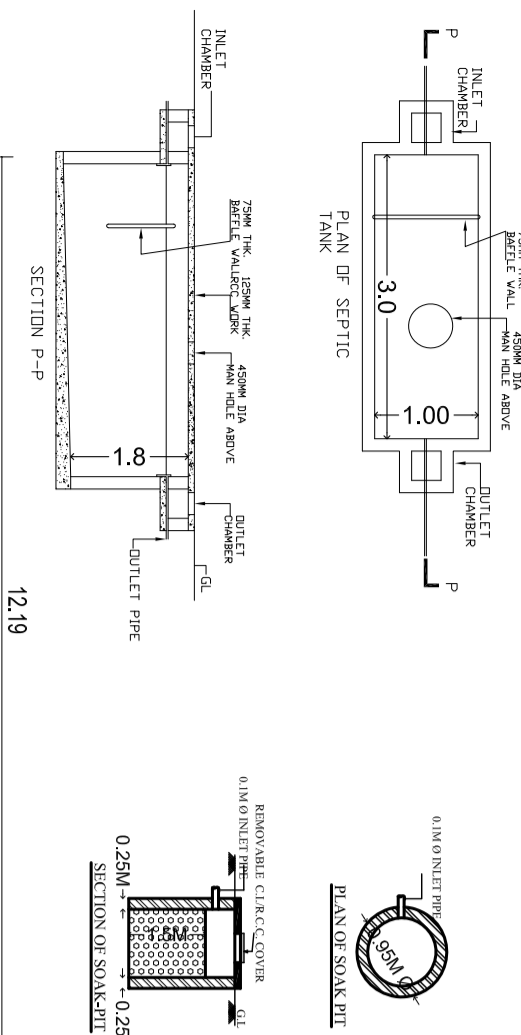

SECTION P-P

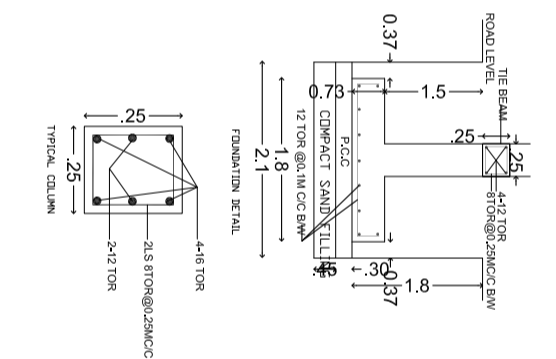
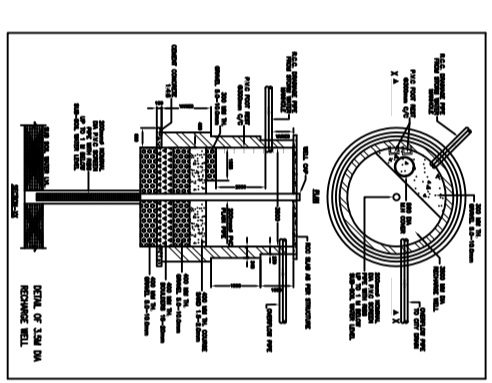
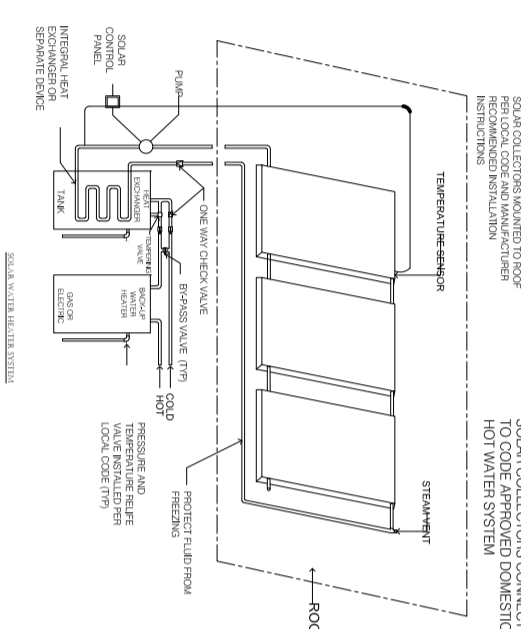

SECTION A-A'

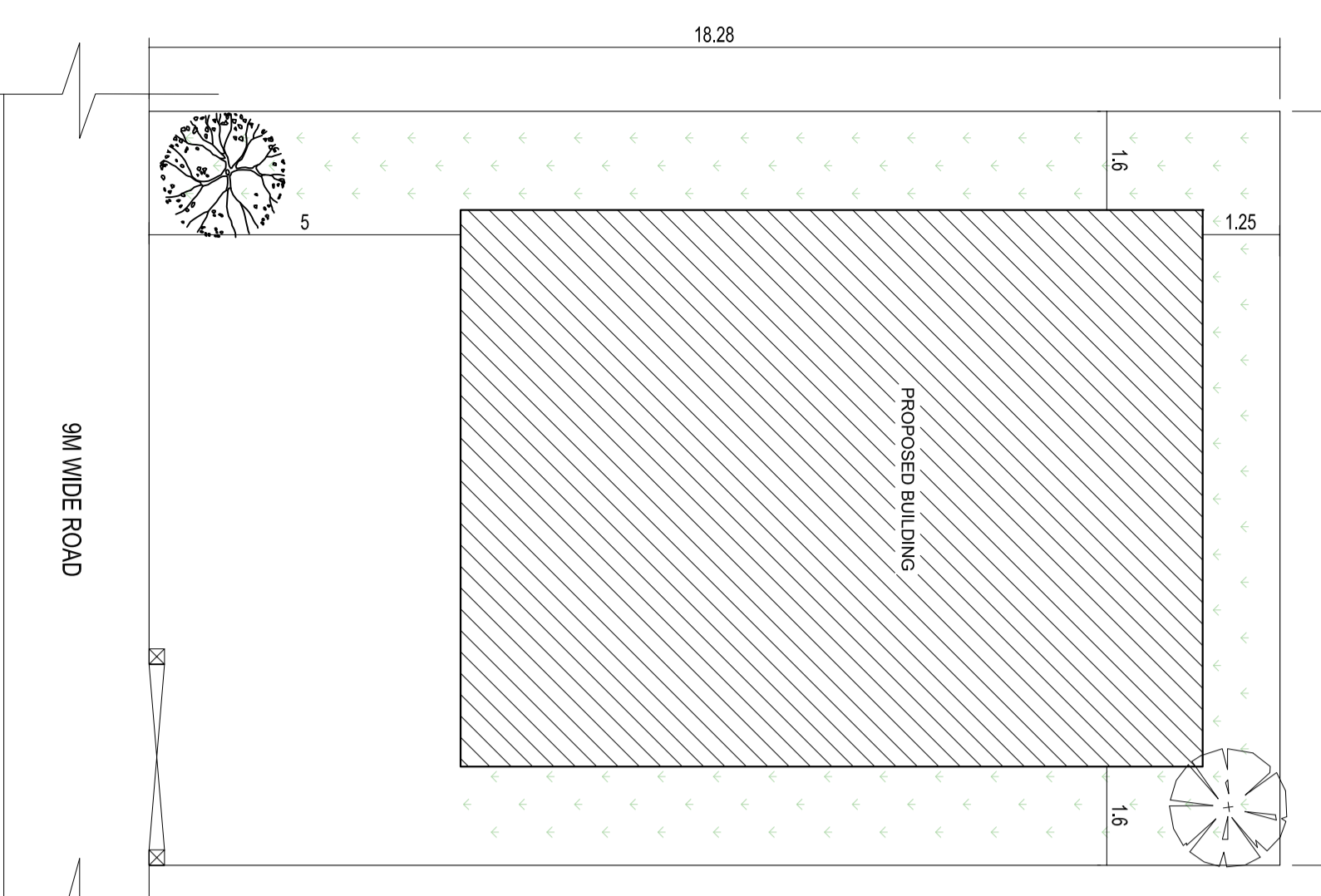
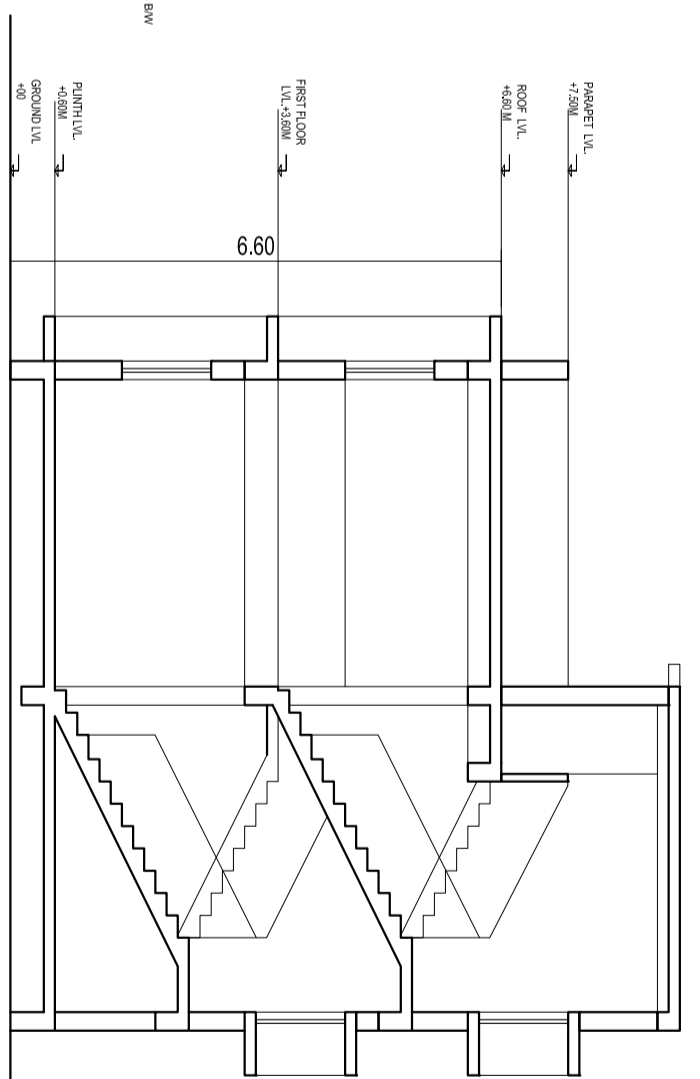

LAYOUT PLAN

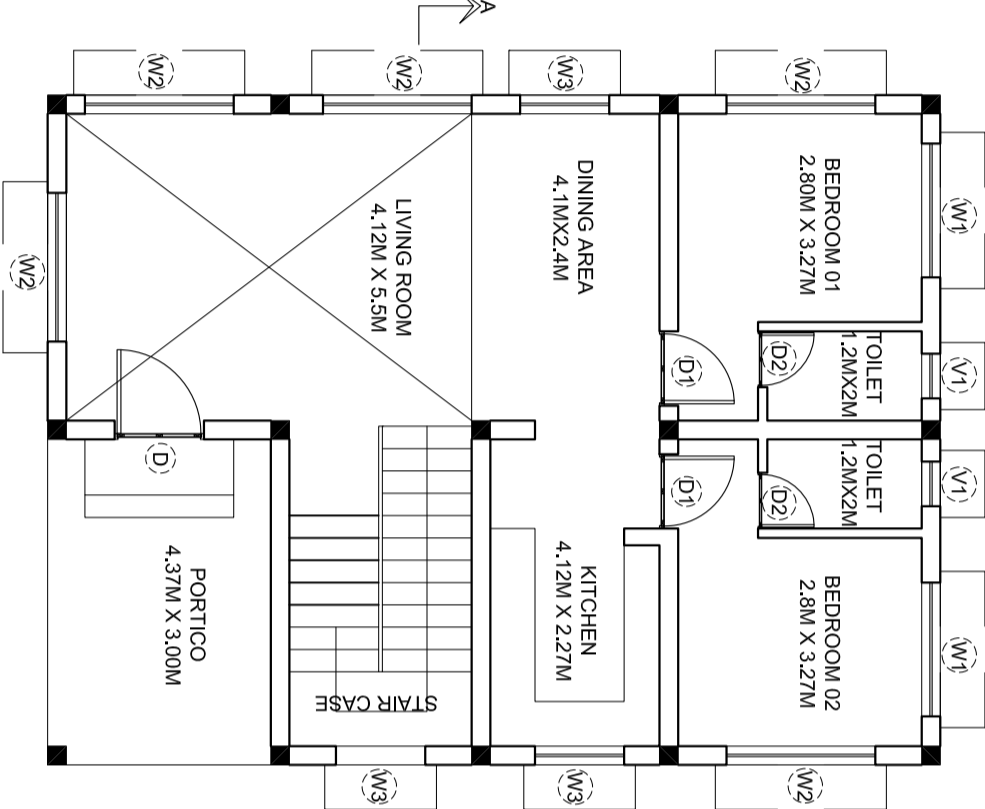

GROUND FLOOR PLAN

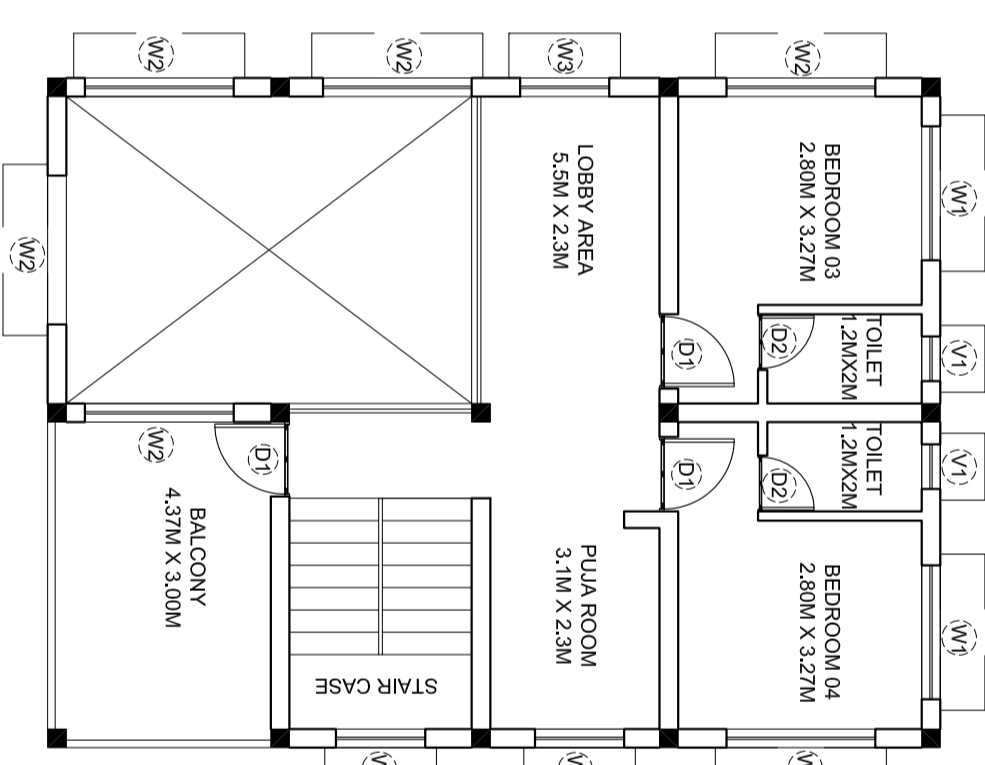

FIRST FLOOR PLAN

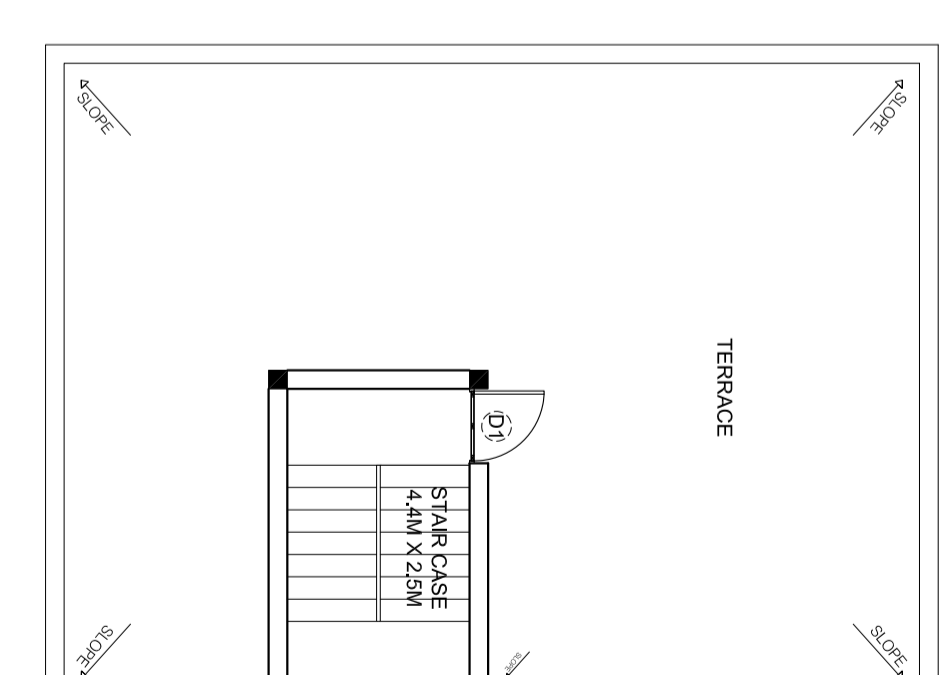

ROOF PLAN

DRAWING TITLE

PROPOSED G + 1 STORED RESIDENTIAL HOUSE

THIS IS A STANDARDIZED PRE-APPROVED PLAN PROVIDED BY

