

SANCTION TEXT

APPROVING AUTHORITY DIGITAL SIGNATURE

DOOR & WINDOW SCHEDULE

S.L. NO.	TYPE	SIZE	DESCRIPTION
1	D	1.07 X 2.13	PANELLED DOOR
2	D1	0.91 X 2.13	PANELLED DOOR
3	D2	0.76 X 2.13	PANELLED DOOR
4	V	1.52 X 1.37	MS. GLAZED WINDOW
5	V1	0.91 X 1.37	MS. GLAZED WINDOW
6	V2	1.22 X 1.14	MS. GLAZED WINDOW
7	V	0.61 X 0.61	MS. GLAZED VENTILATOR

AREA AND BUILDING PARAMETERS

PLOT DIMENSIONS (IN FEET)	40' X 50'
PLOT DIMENSIONS (IN MET)	12.19M X 15.24M
PLOT AREA	222.95 SQMT
GROUND FLOOR BUILT UP AREA	160.69 SQMT
FIRST FLOOR BUILT UP AREA	113.68 SQMT
SECOND FLOOR BUILT UP AREA	113.68 SQMT
TOTAL FAR AREA	388.05 SQMT
FLOOR AREA RATIO (FAR)	1.74
BUILDING HEIGHT	9.45 MT
PLANTATION AREA	SQMT
NUMBER OF TREES PROVIDED	NOS

APPLICANT DETAILS

NAME OF APPLICANT	
ADDRESS	
CONTACT NUMBER	

LAND DETAILS

REVENUE VILLAGE	
REVENUE PLOT NO	
SCHEME PLOT NO/ LAYOUT	
PLOT NO/ SUB PLOT NO	
KHATA NUMBER	

SITE PLAN

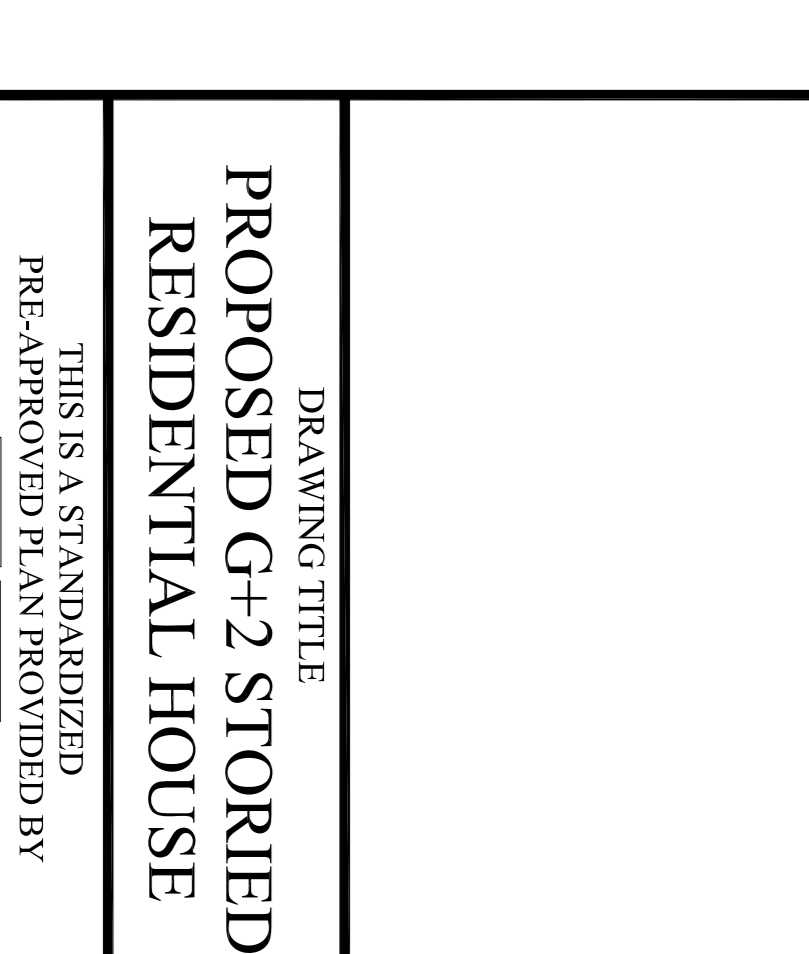
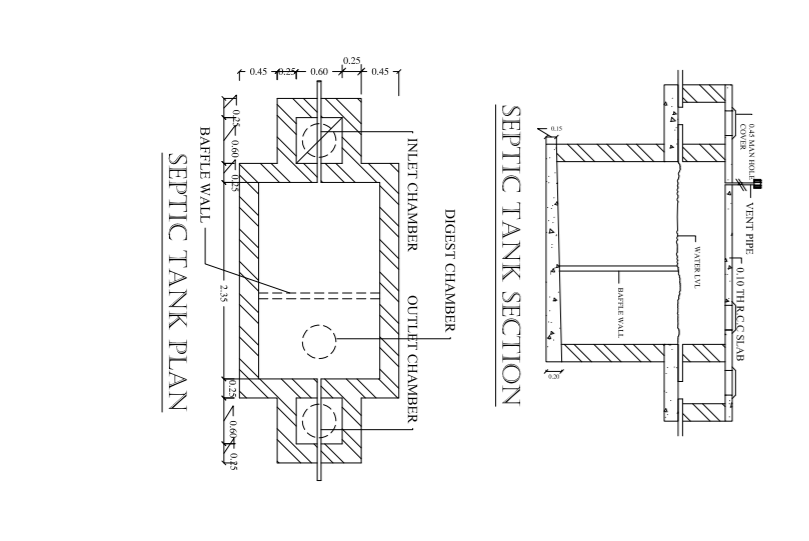
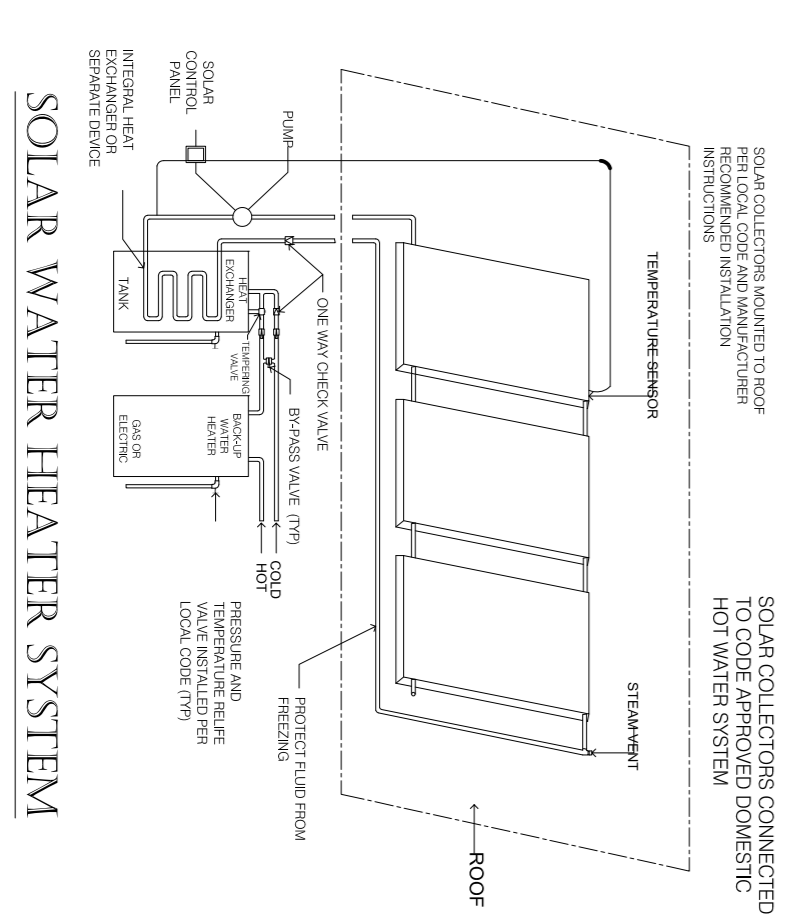
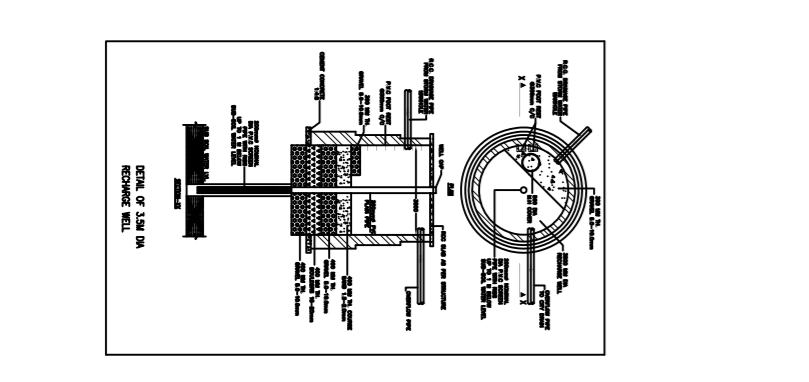
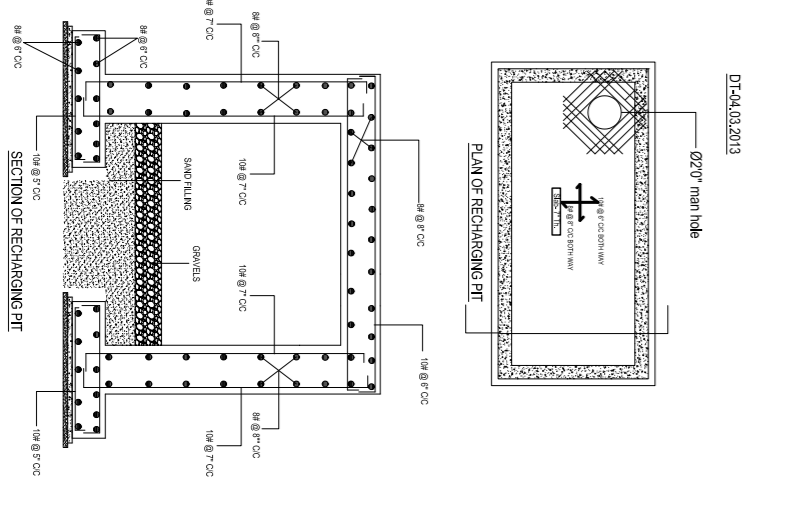
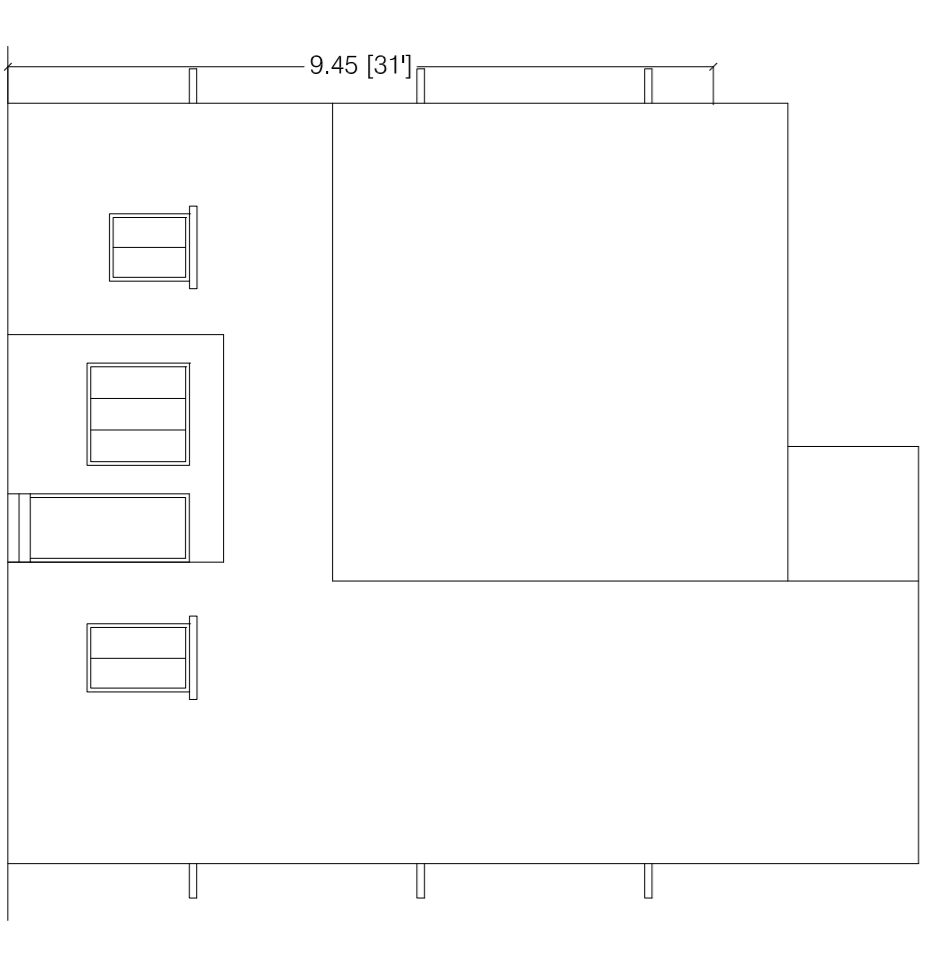
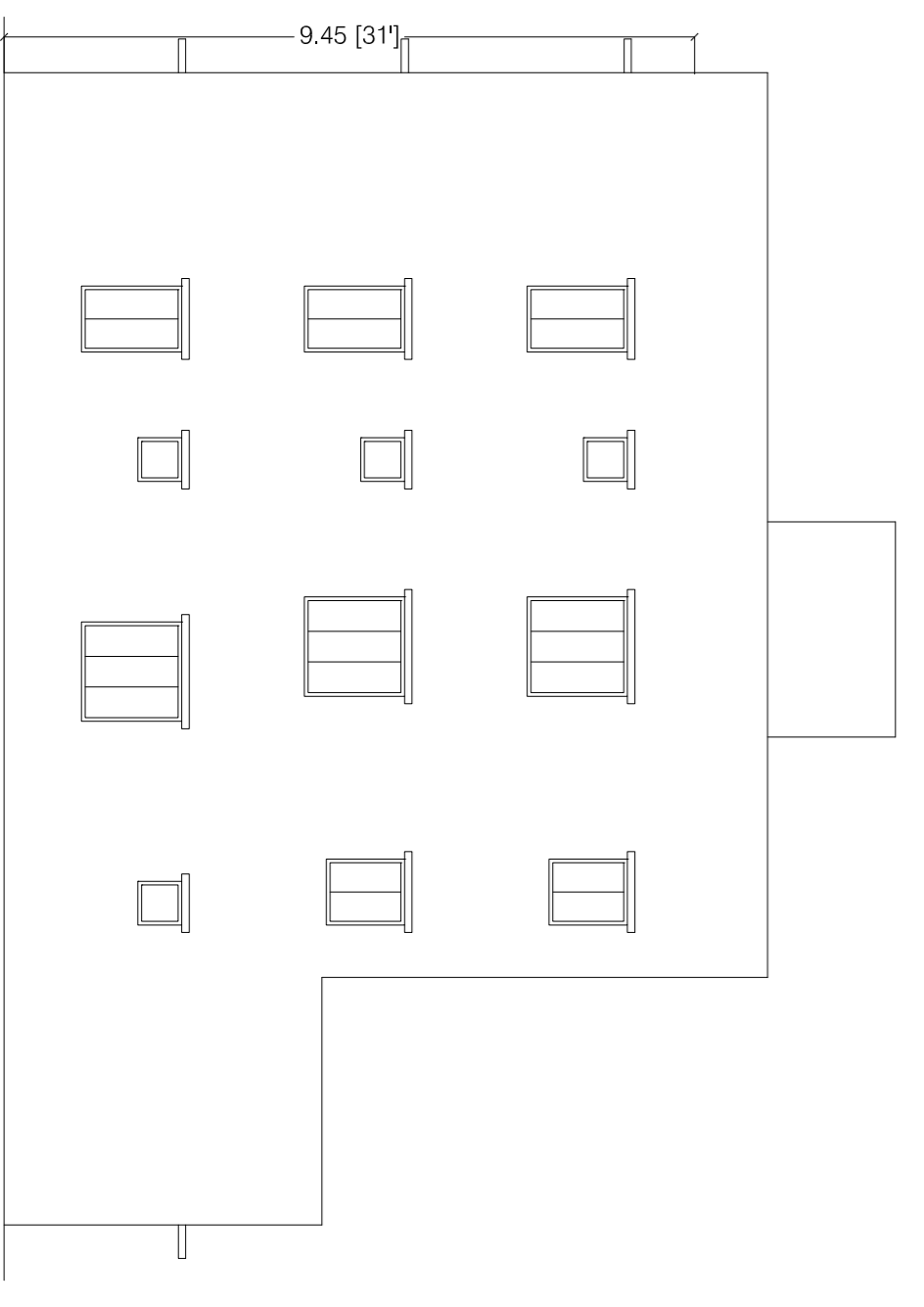
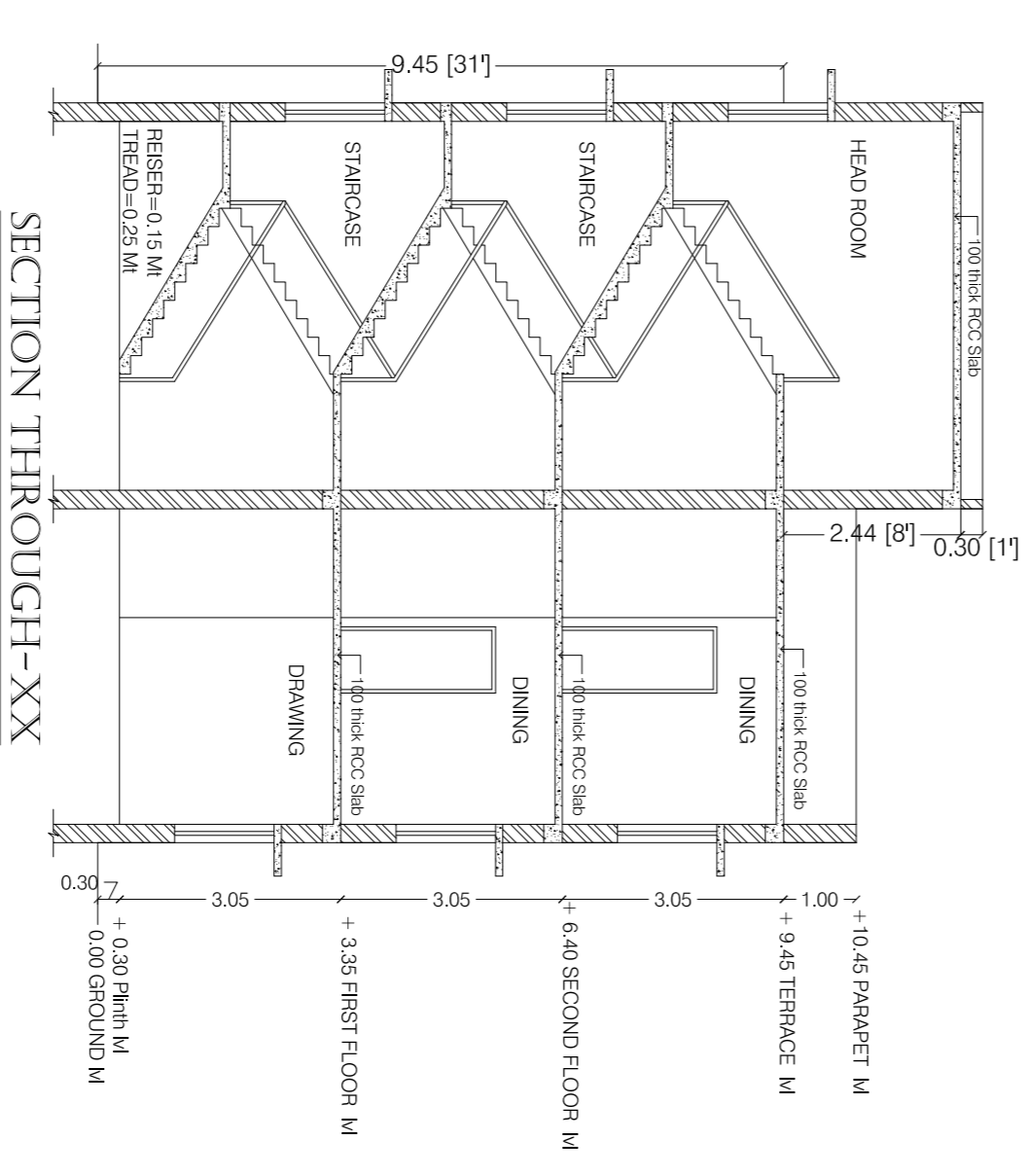
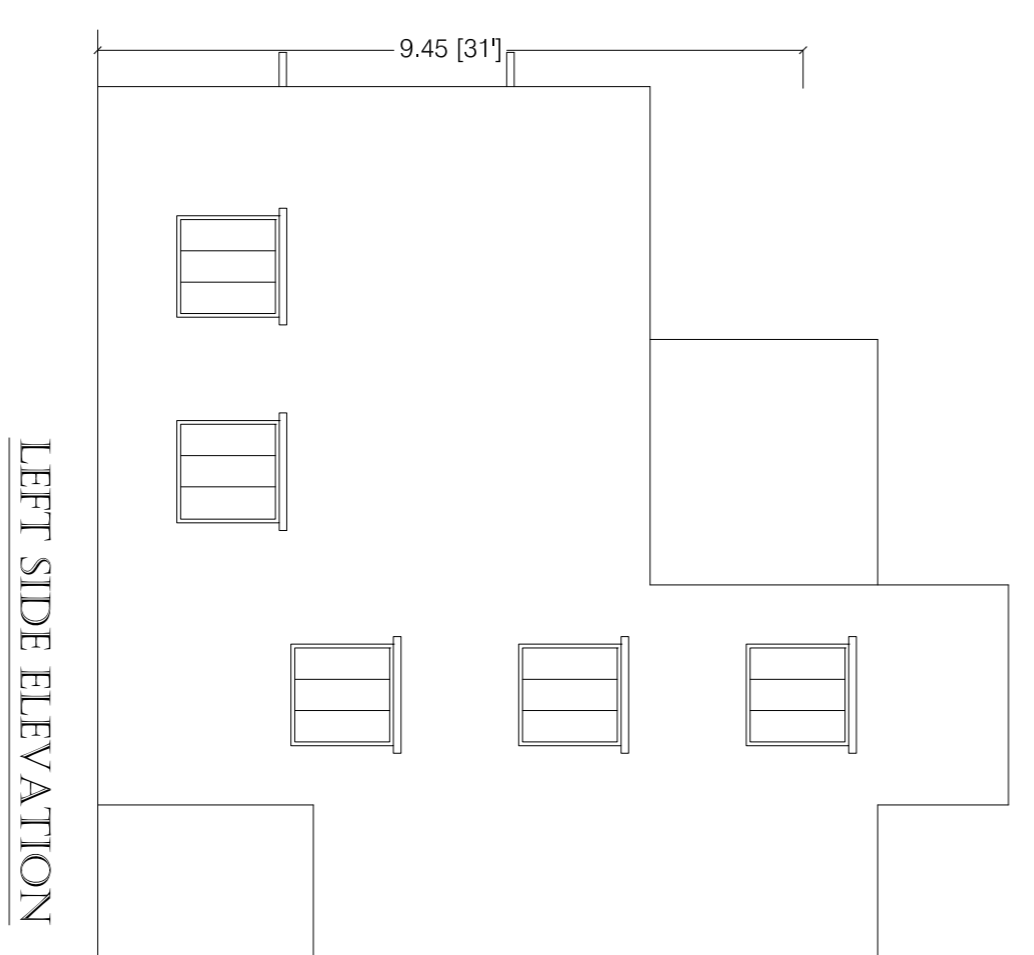
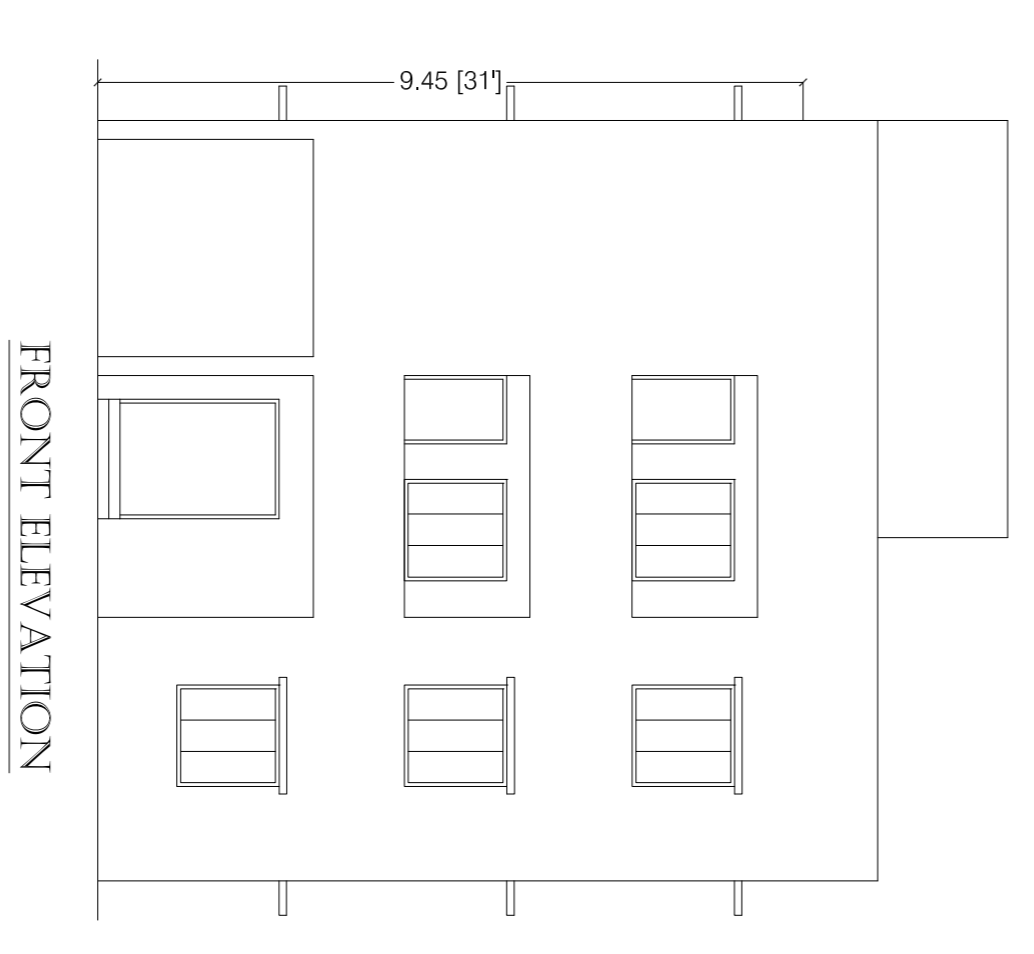
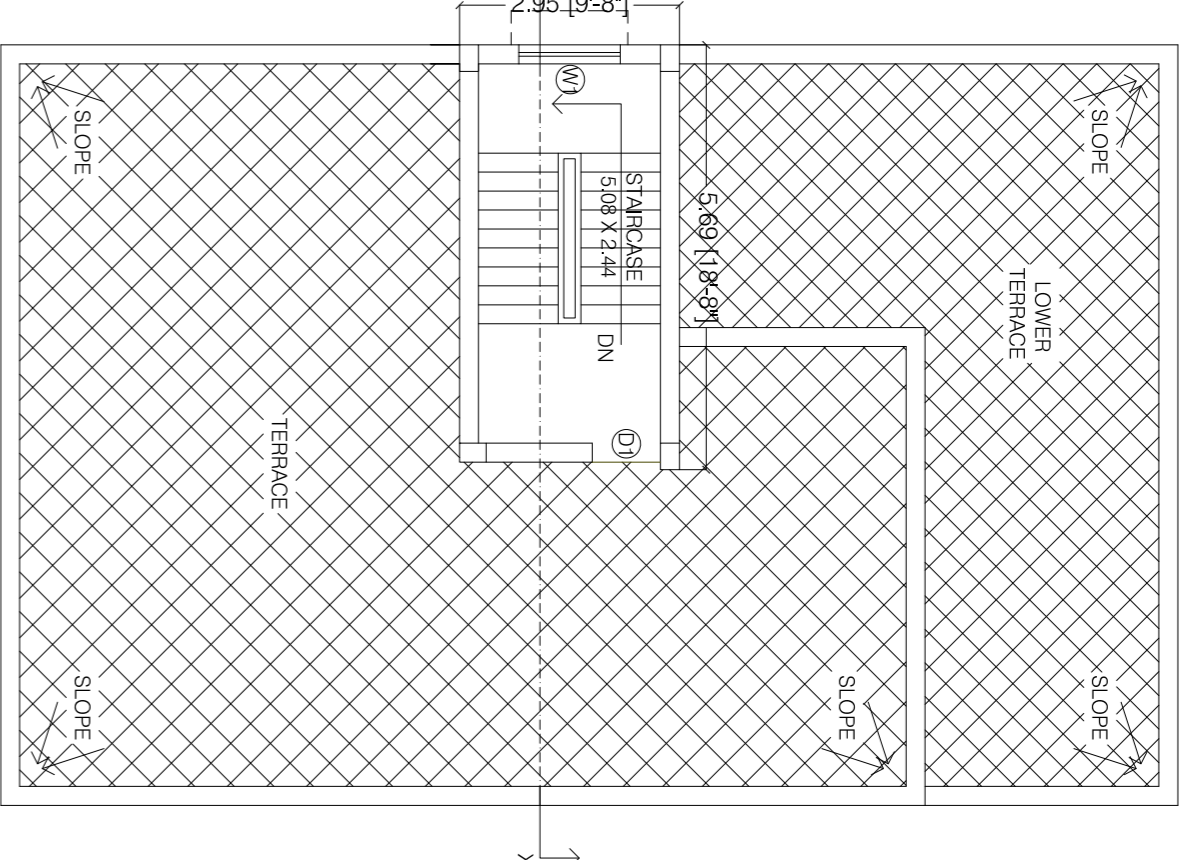
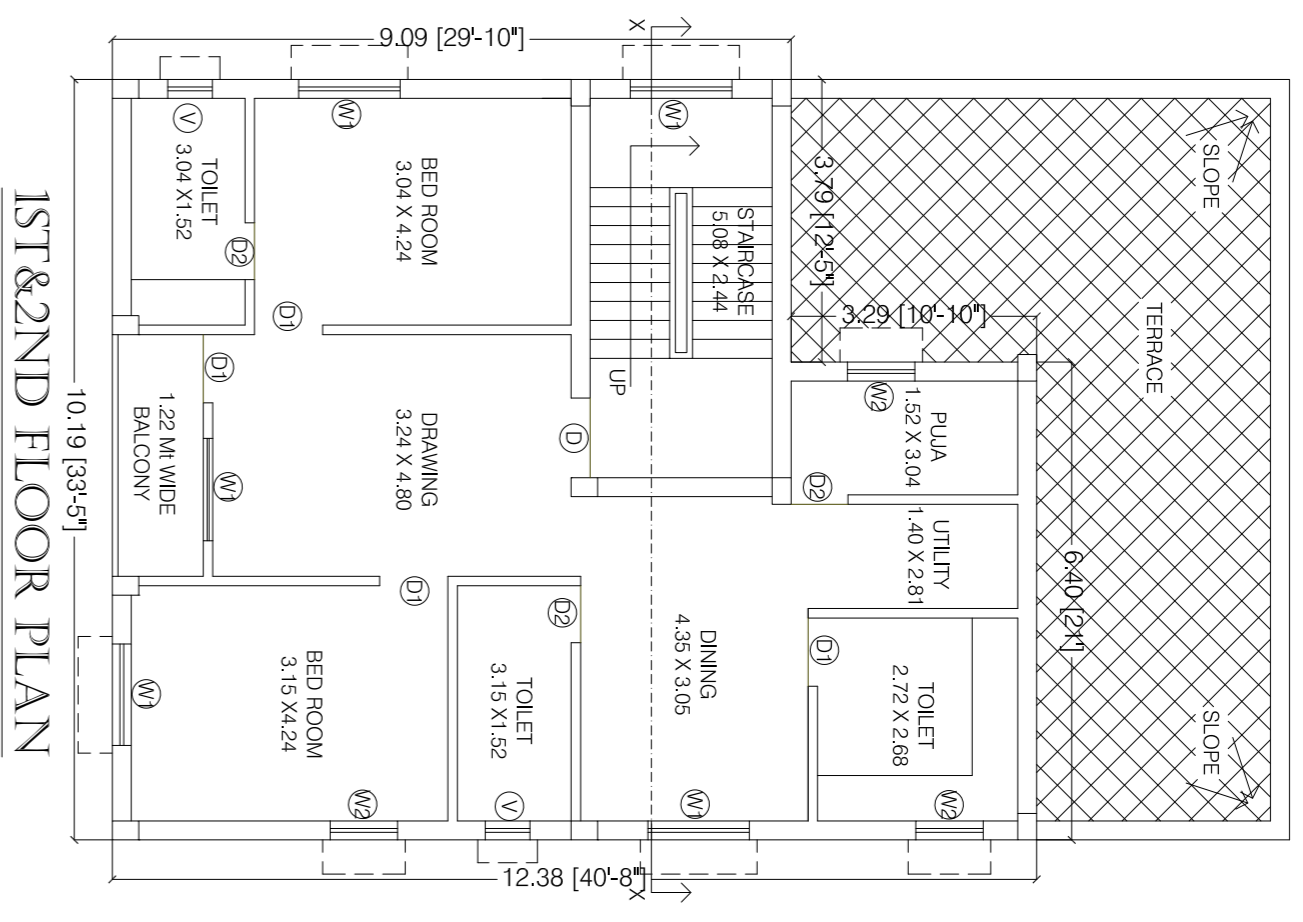
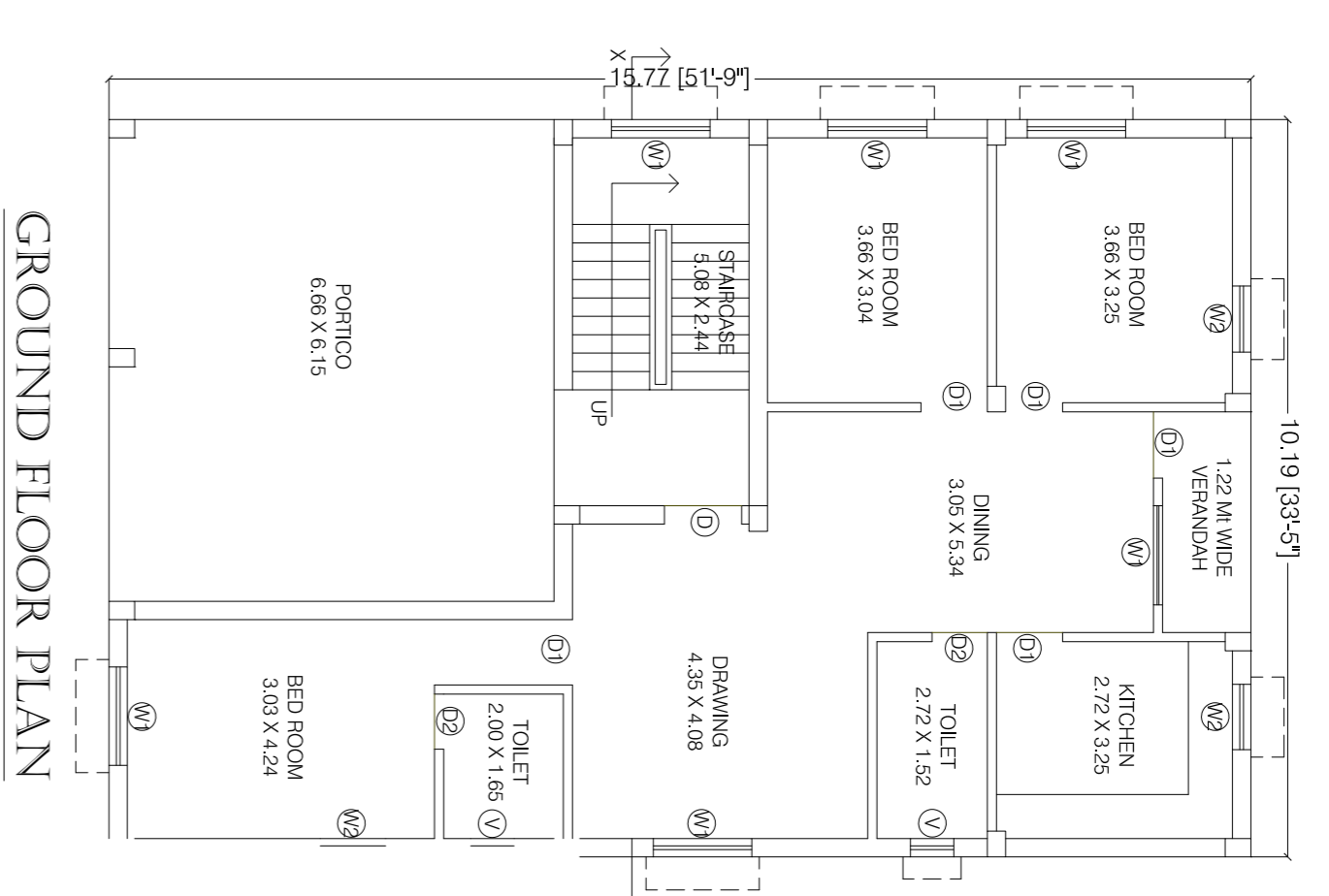
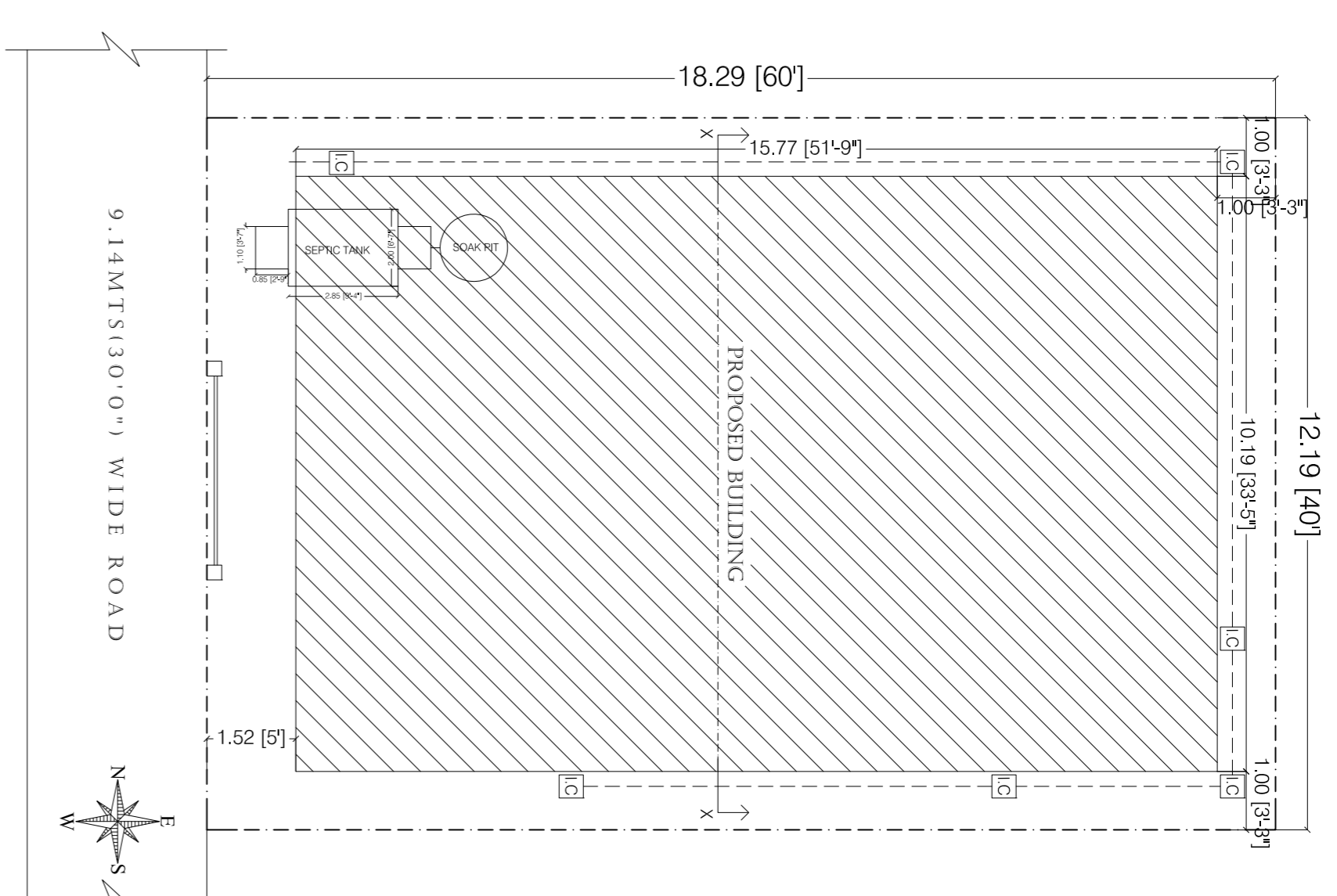

DRAWING TITLE

**PROPOSED G+2 STORIED RESIDENTIAL HOUSE**

THIS IS A STANDARDIZED PRE-APPROVED PLAN PROVIDED BY

