

SANCTION TEXT

APPROVING AUTHORITY DIGITAL SIGNATURE

| DOOR & WINDOW SCHEDULE |      |                                   |
|------------------------|------|-----------------------------------|
| SL. NO.                | TYPE | DESCRIPTION                       |
| 1                      | D    | 1.07 X 2.13 PANELLED DOOR         |
| 2                      | D1   | 0.91 X 2.13 PANELLED DOOR         |
| 3                      | D2   | 0.76 X 2.13 PANELLED DOOR         |
| 4                      | W    | 1.52 X 1.37 MS. GLAZED WINDOW     |
| 5                      | W1   | 0.91 X 1.37 MS. GLAZED WINDOW     |
| 6                      | W2   | 1.22 X 1.14 MS. GLAZED WINDOW     |
| 7                      | V    | 0.61 X 0.61 MS. GLAZED VENTILATOR |

| AREA AND BUILDING PARAMETERS |                  |
|------------------------------|------------------|
| PLOT DIMENSIONS (IN FEET)    | 40' x 50'        |
| PLOT DIMENSIONS (IN MT)      | 12.20 M x 15.24M |
| PLOT AREA                    | 185.87 SQMT      |
| GROUND FLOOR BUILT UP AREA   | 87.91 SQMT       |
| FIRST FLOOR BUILT UP AREA    | 87.91 SQMT       |
| TOTAL BUILT UP AREA          | 175.82 SQMT      |
| FLOOR AREA RATIO (FAR)       | 0.945            |
| BUILDING HEIGHT              | 6.40 MT          |
| PLANTATION AREA              | 71.12 SQMT       |
| NUMBER OF TREES PROVIDED     | 03 NOS           |

| APPLICANT DETAILS |  |
|-------------------|--|
| NAME OF APPLICANT |  |
| ADDRESS           |  |
| CONTACT NUMBER    |  |

| LAND DETAILS          |  |
|-----------------------|--|
| REVENUE VILLAGE       |  |
| REVENUE PLOT NO       |  |
| SCHEME PLOT NO/LAYOUT |  |
| PLOT NO./SUB PLOT NO  |  |
| KHATA NUMBER          |  |

SITE PLAN

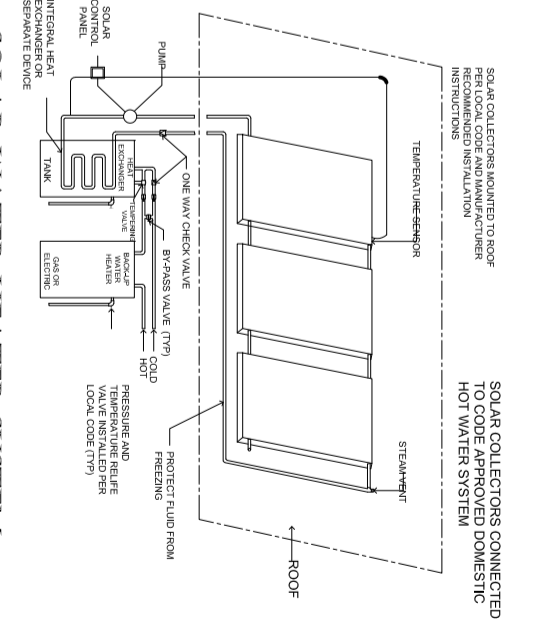
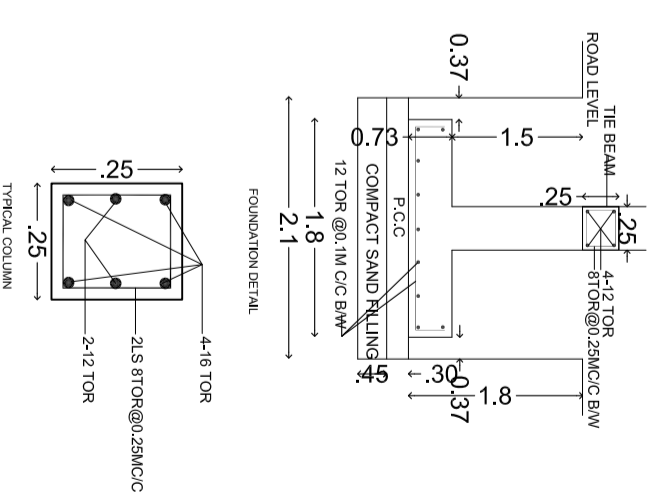
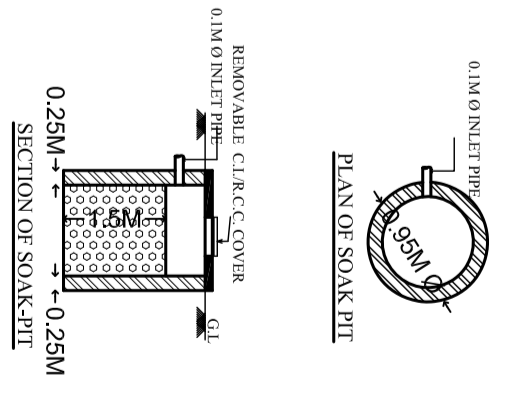
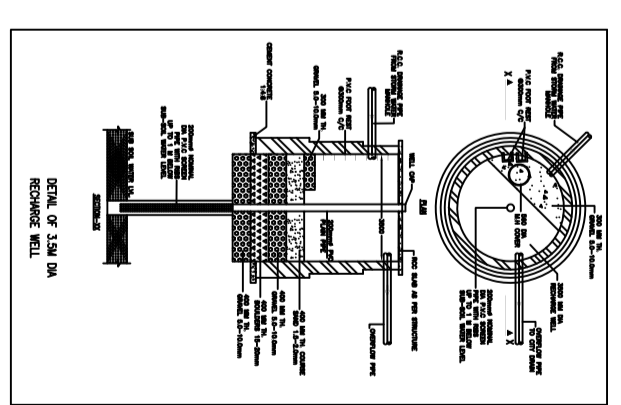
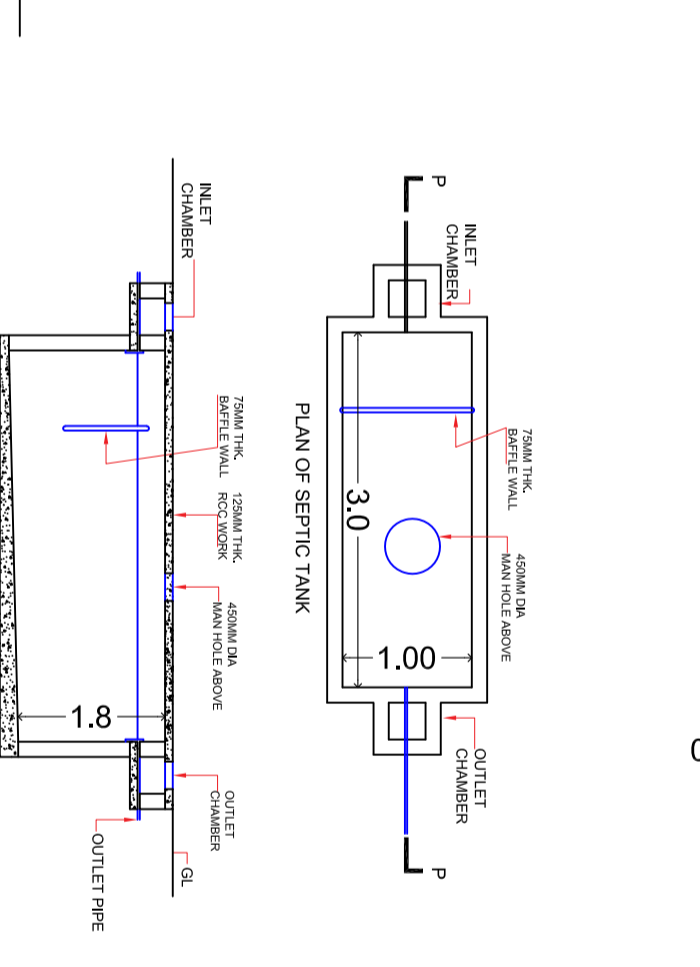
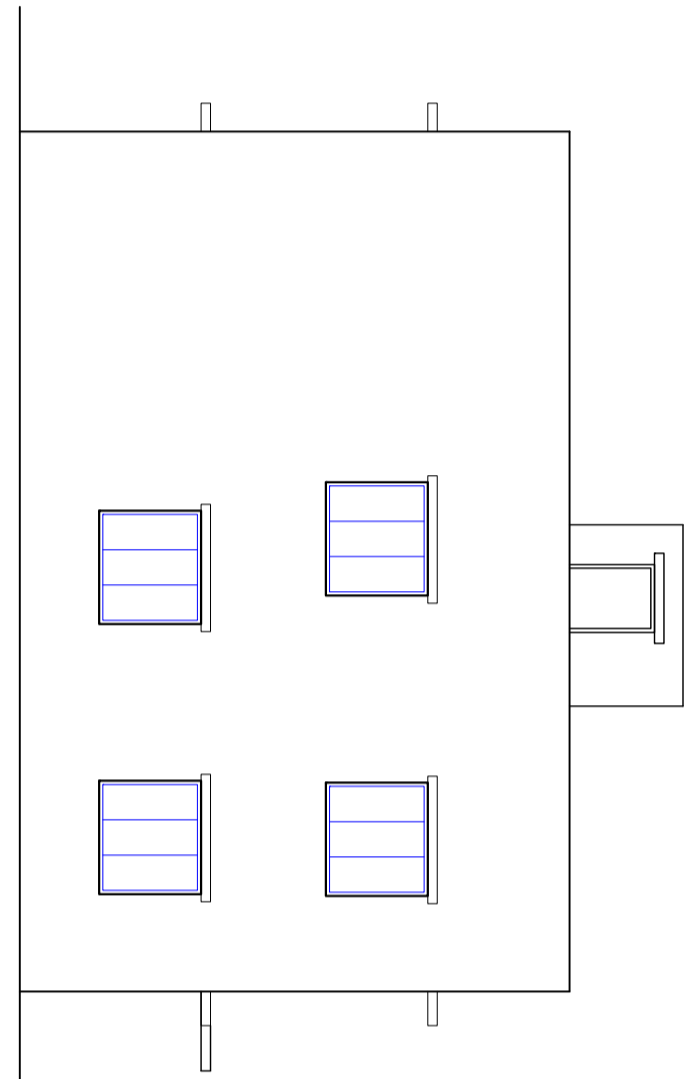
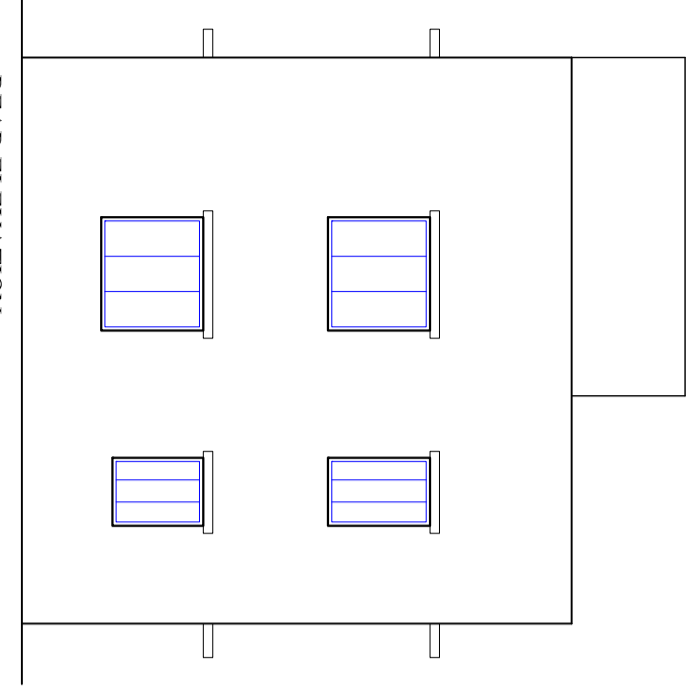
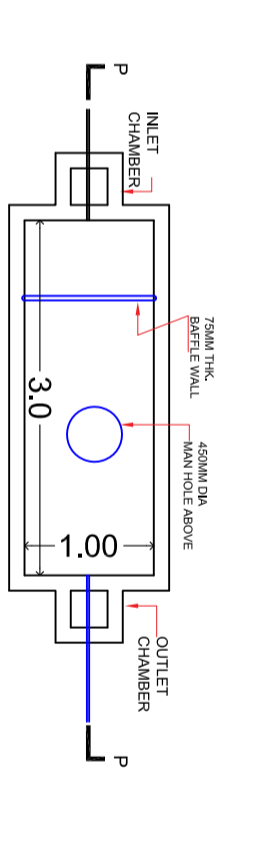
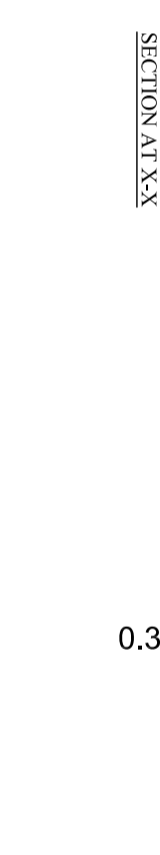
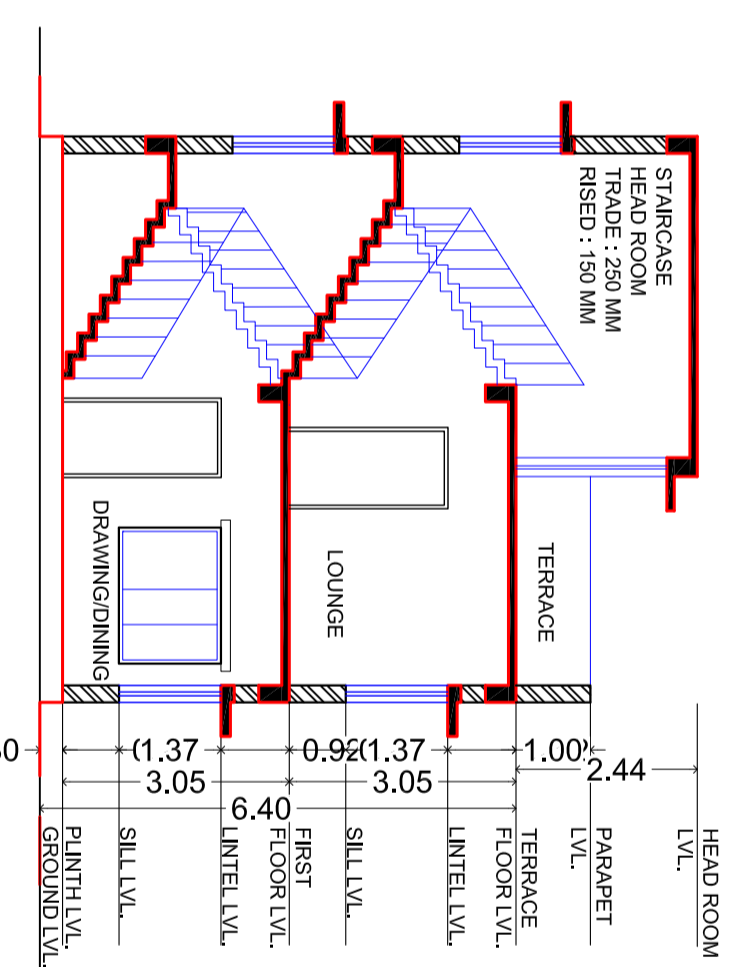
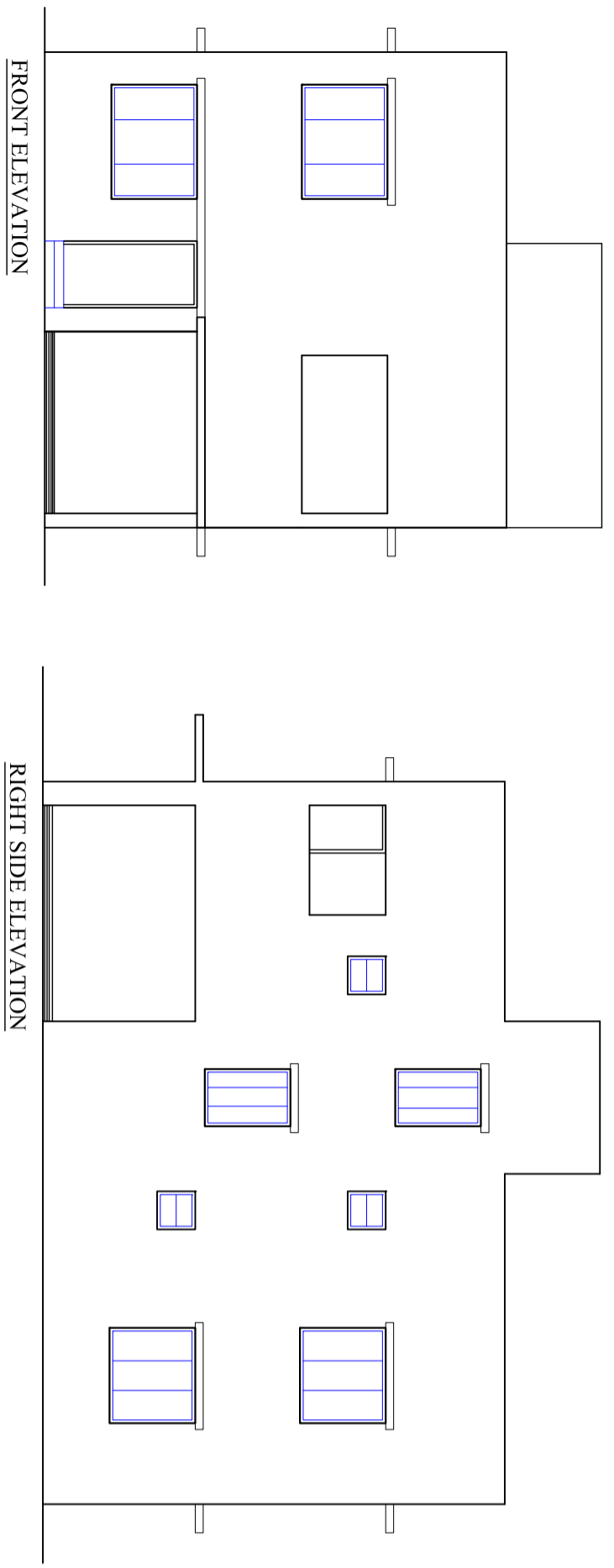
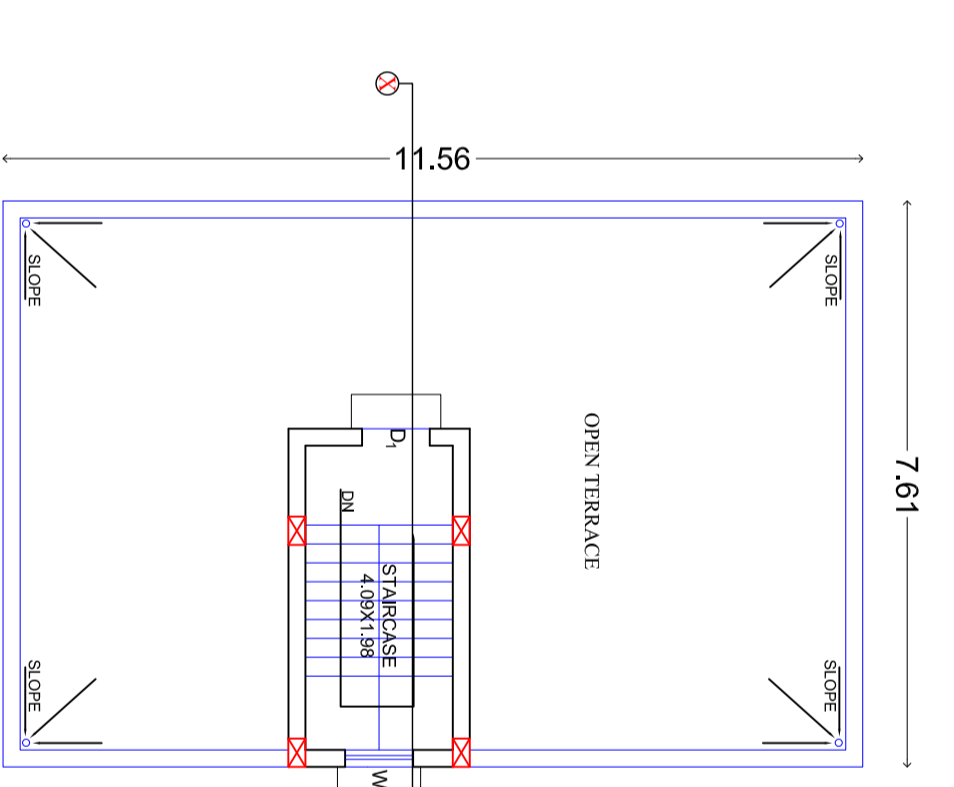
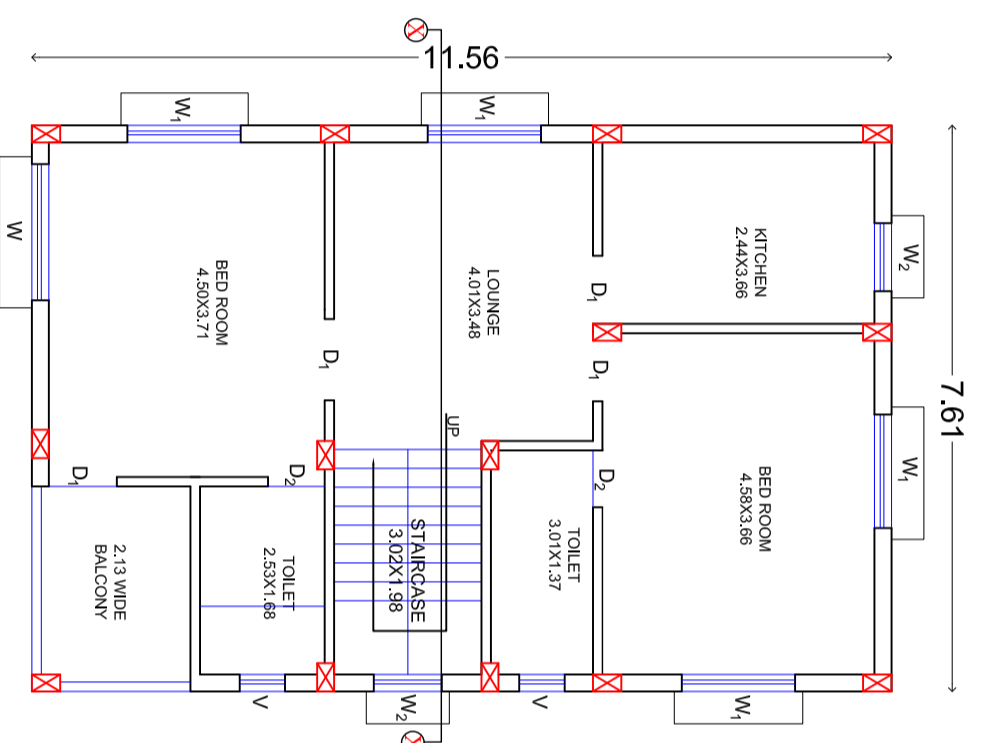
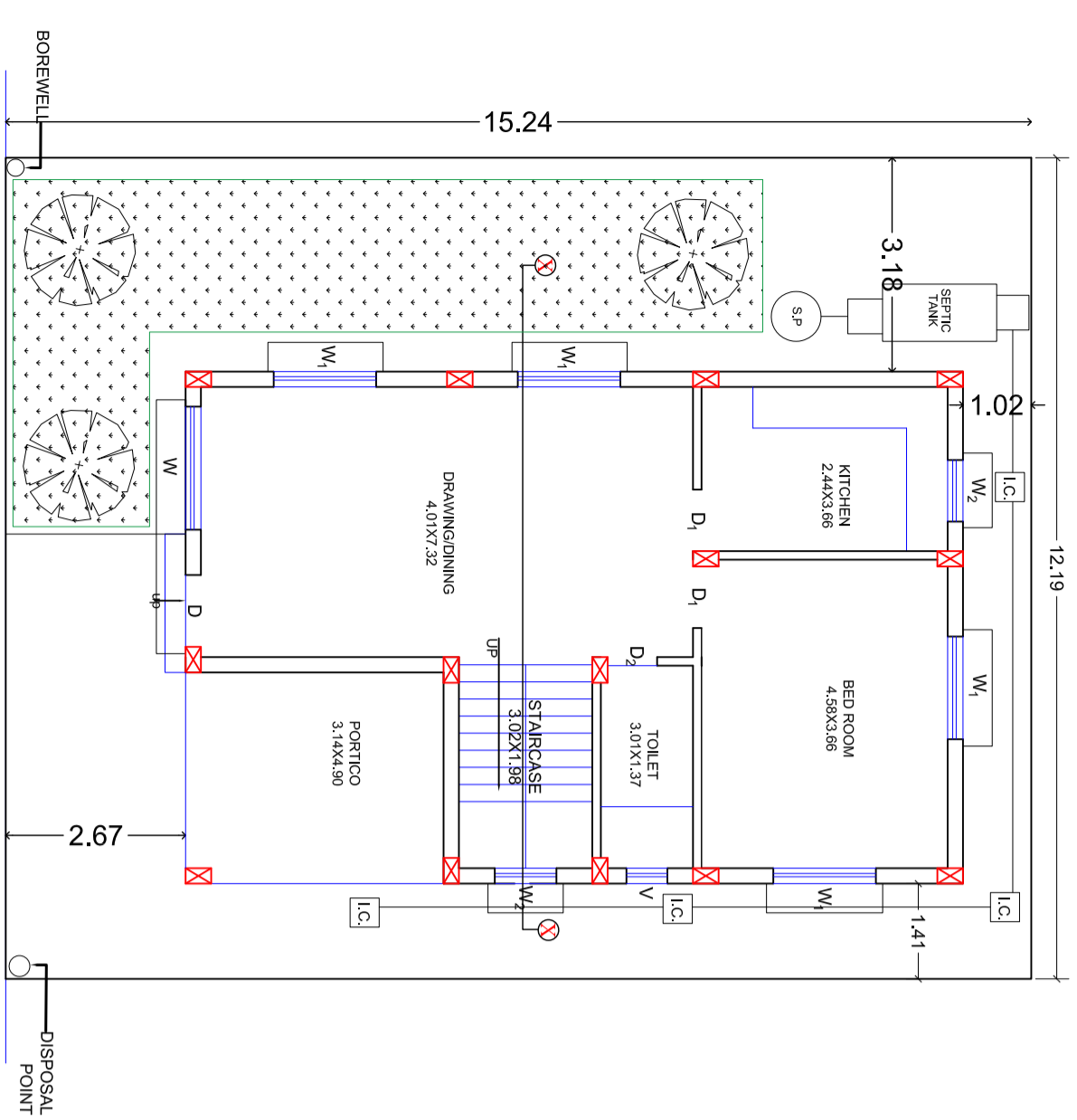

DRAWING TITLE  
**PROPOSED G+1 STOREIED RESIDENTIAL HOUSE**  
THIS IS A STANDARDIZED PRE-APPROVED PLAN PROVIDED BY

