

Pre-Approved Building Plan No  
**40501803**

SANCTION TEXT

APPROVING AUTHORITY DIGITAL SIGNATURE

DOOR & WINDOW SCHEDULE		
SL. NO.	TYPE	DESCRIPTION
1	D	1.07 X 2.13 PANELLED DOOR
2	D1	0.91 X 2.13 PANELLED DOOR
3	D2	0.76 X 2.13 PANELLED DOOR
4	W	1.52 X 1.37 MS. GLAZED WINDOW
5	W1	0.91 X 1.37 MS. GLAZED WINDOW
6	W2	1.22 X 1.14 MS. GLAZED WINDOW
7	V	0.61 X 0.61 MS. GLAZED VENTILATOR

AREA AND BUILDING PARAMETERS	
PLOT DIMENSIONS (IN FEET)	40' X 50'
PLOT DIMENSIONS (IN MT)	12.20 M X 15.25 M
PLOT AREA	185.87 SQMT
GROUND FLOOR BUILT UP AREA	87.91 SQMT
FIRST FLOOR BUILT UP AREA	87.91 SQMT
TOTAL BUILT UP AREA	175.82 SQMT
FLOOR AREA RATIO (FAR)	0.945
BUILDING HEIGHT	6.40 MT
PLANTATION AREA	71.12 SQMT
NUMBER OF TREES PROVIDED	03 NOS

APPLICANT DETAILS	
NAME OF APPLICANT	
ADDRESS	
CONTACT NUMBER	

LAND DETAILS	
REVENUE VILLAGE	
REVENUE PLOT NO	
SCHEME PLOT NO/LAYOUT	
PLOT NO./SUB PLOT NO	
KHATA NUMBER	

SITE PLAN

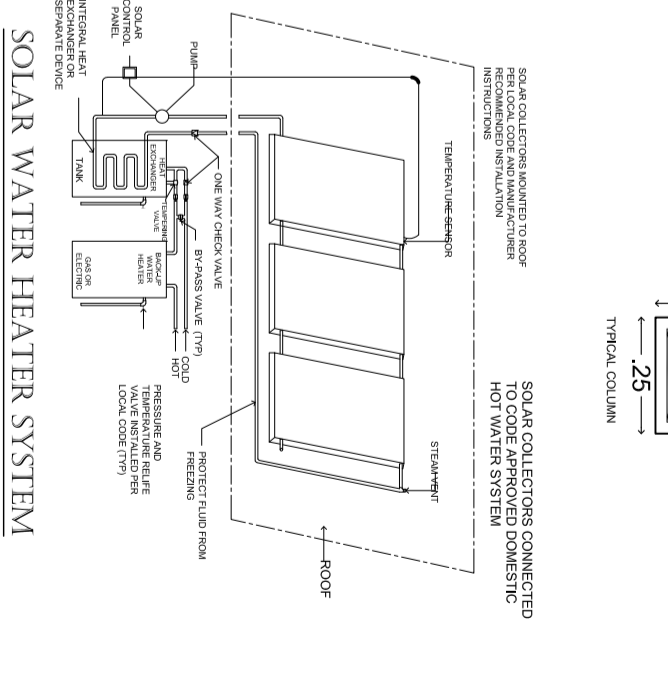
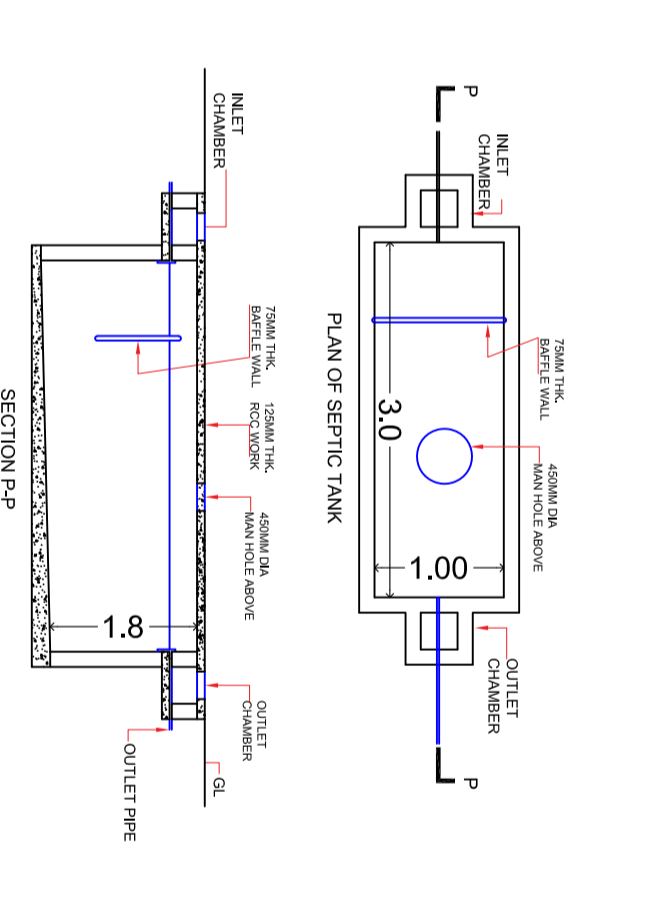
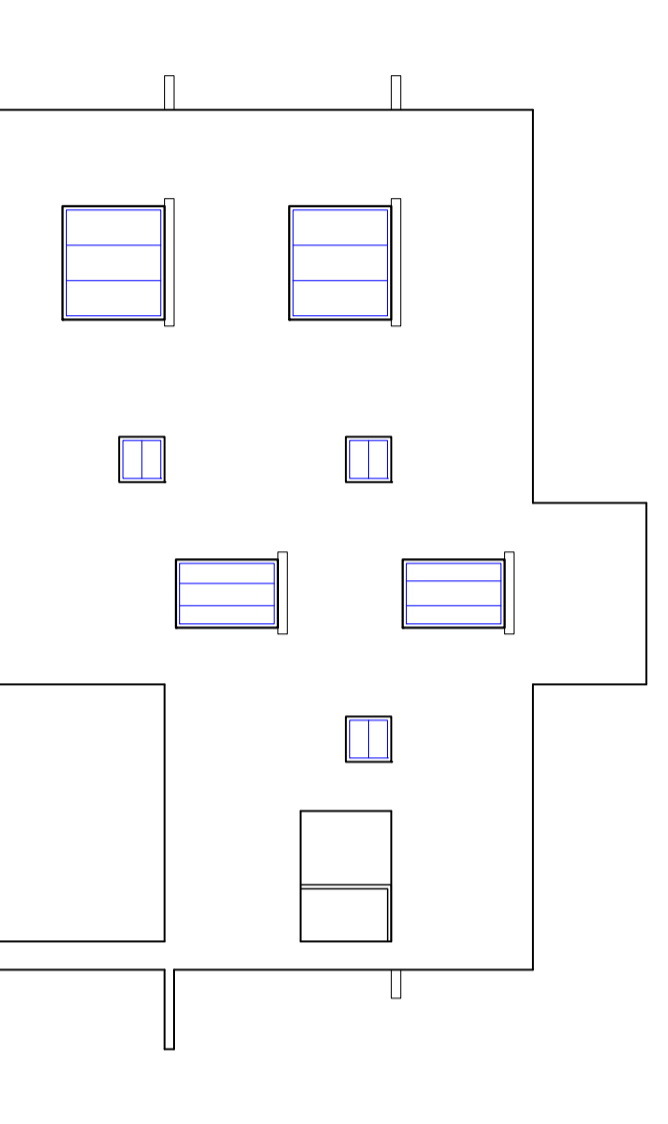
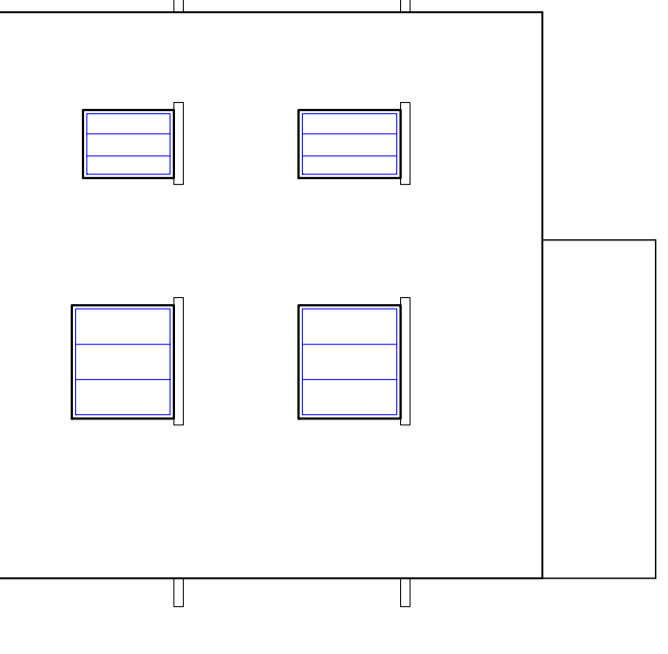
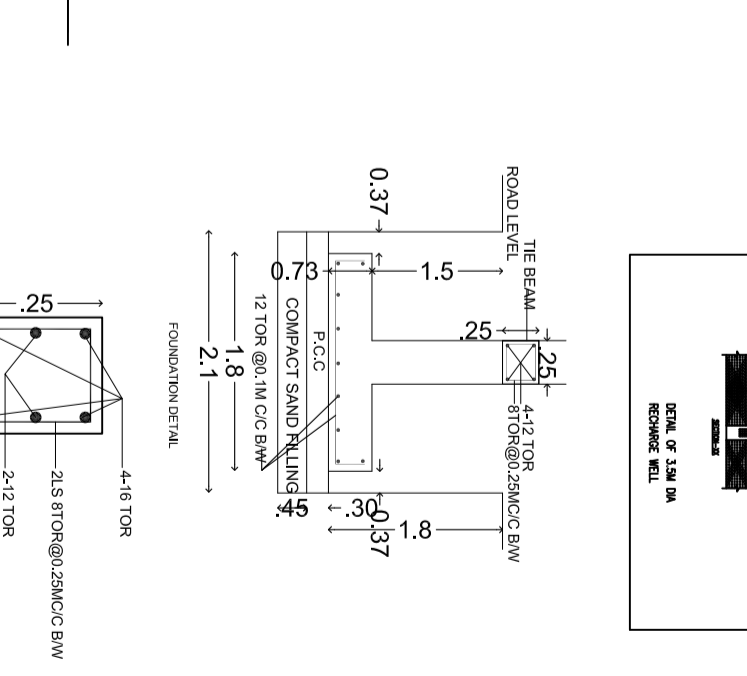
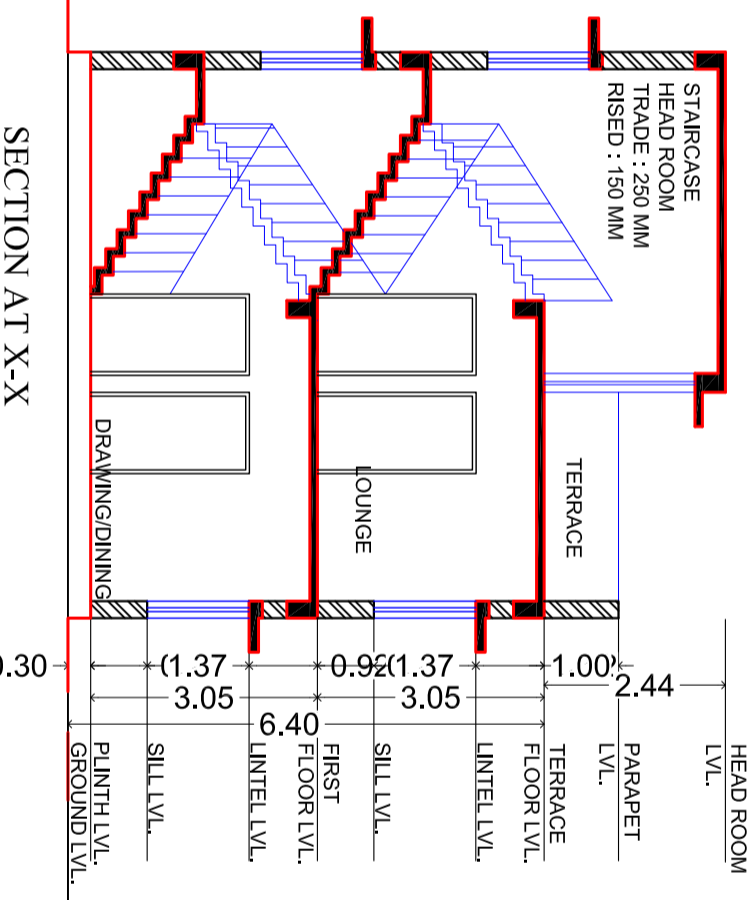
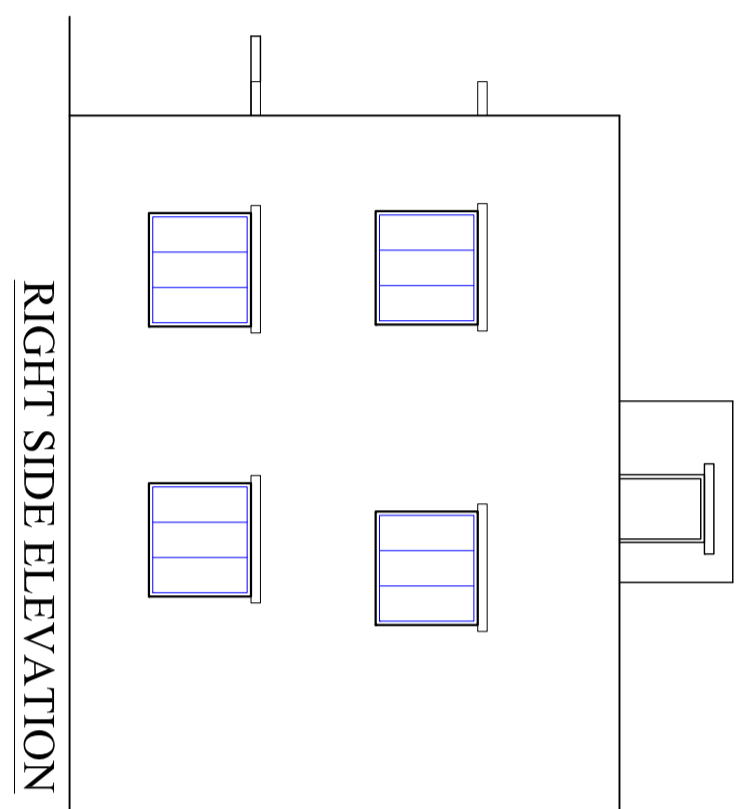
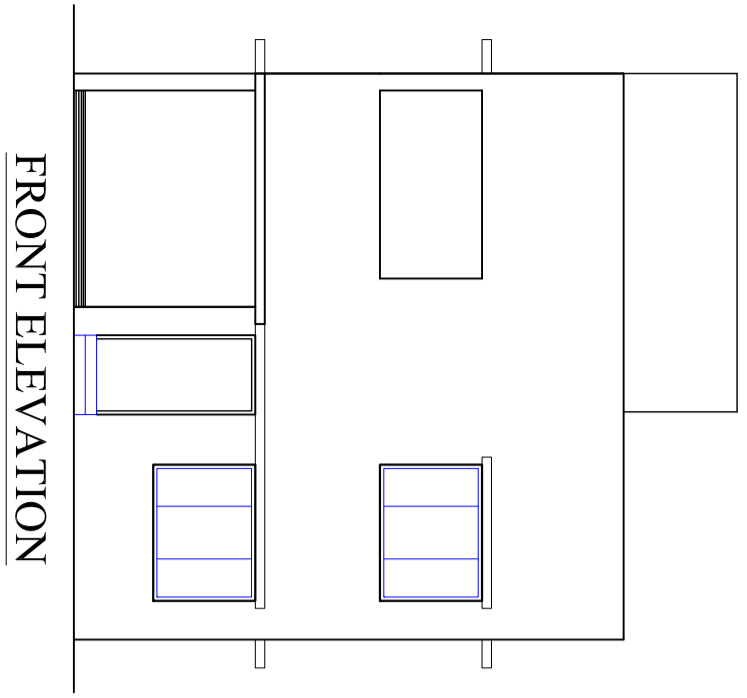
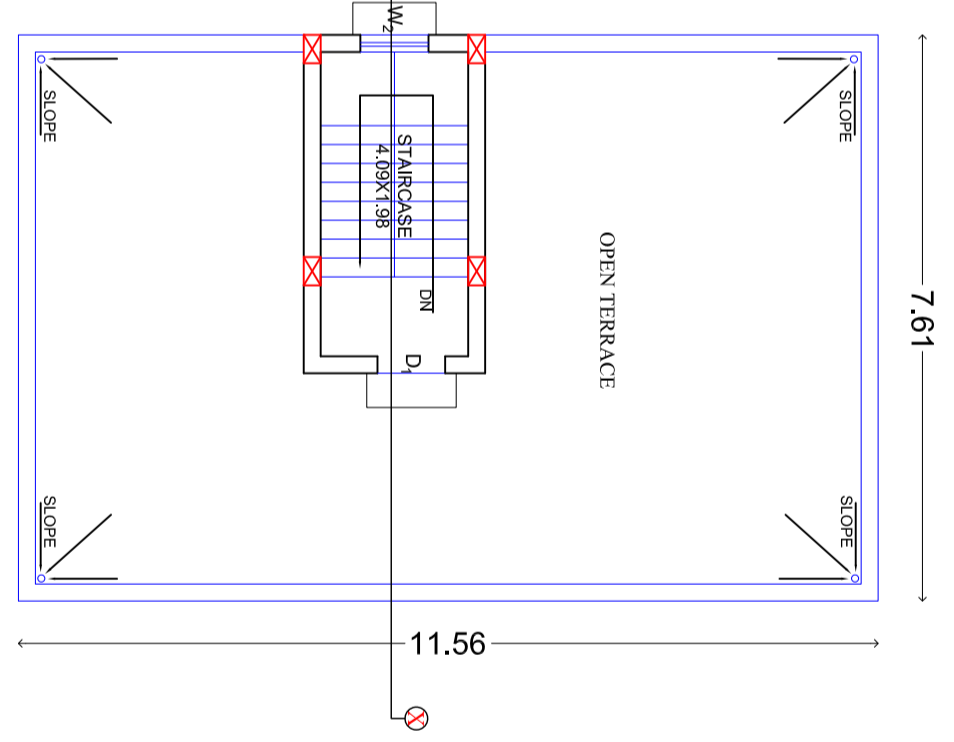
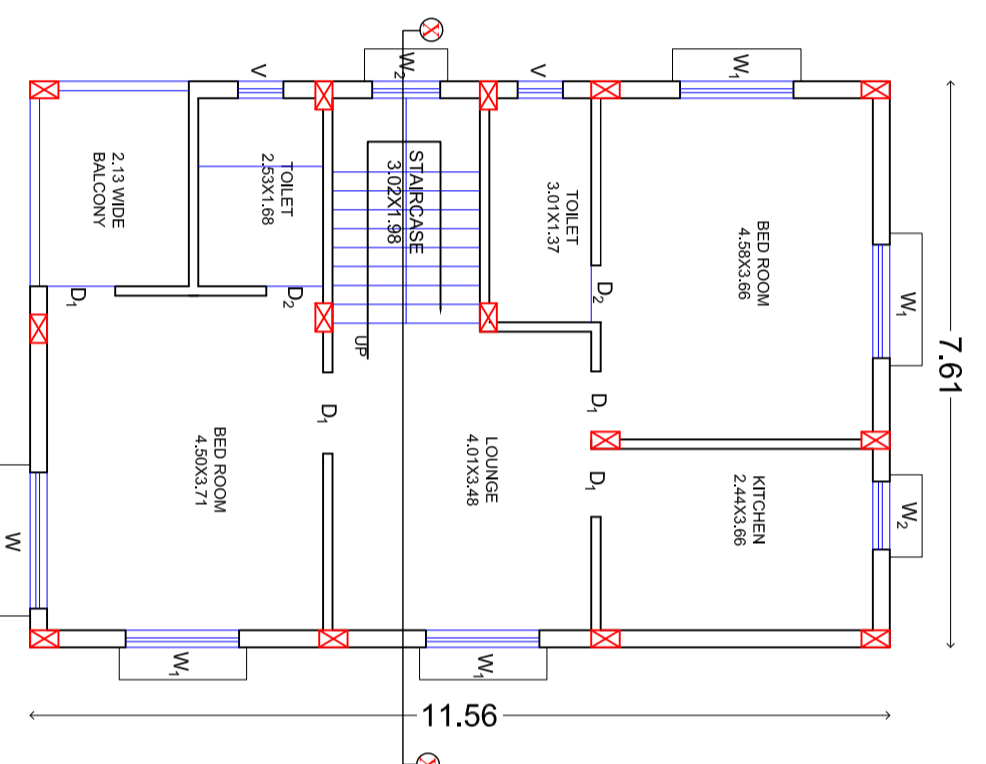
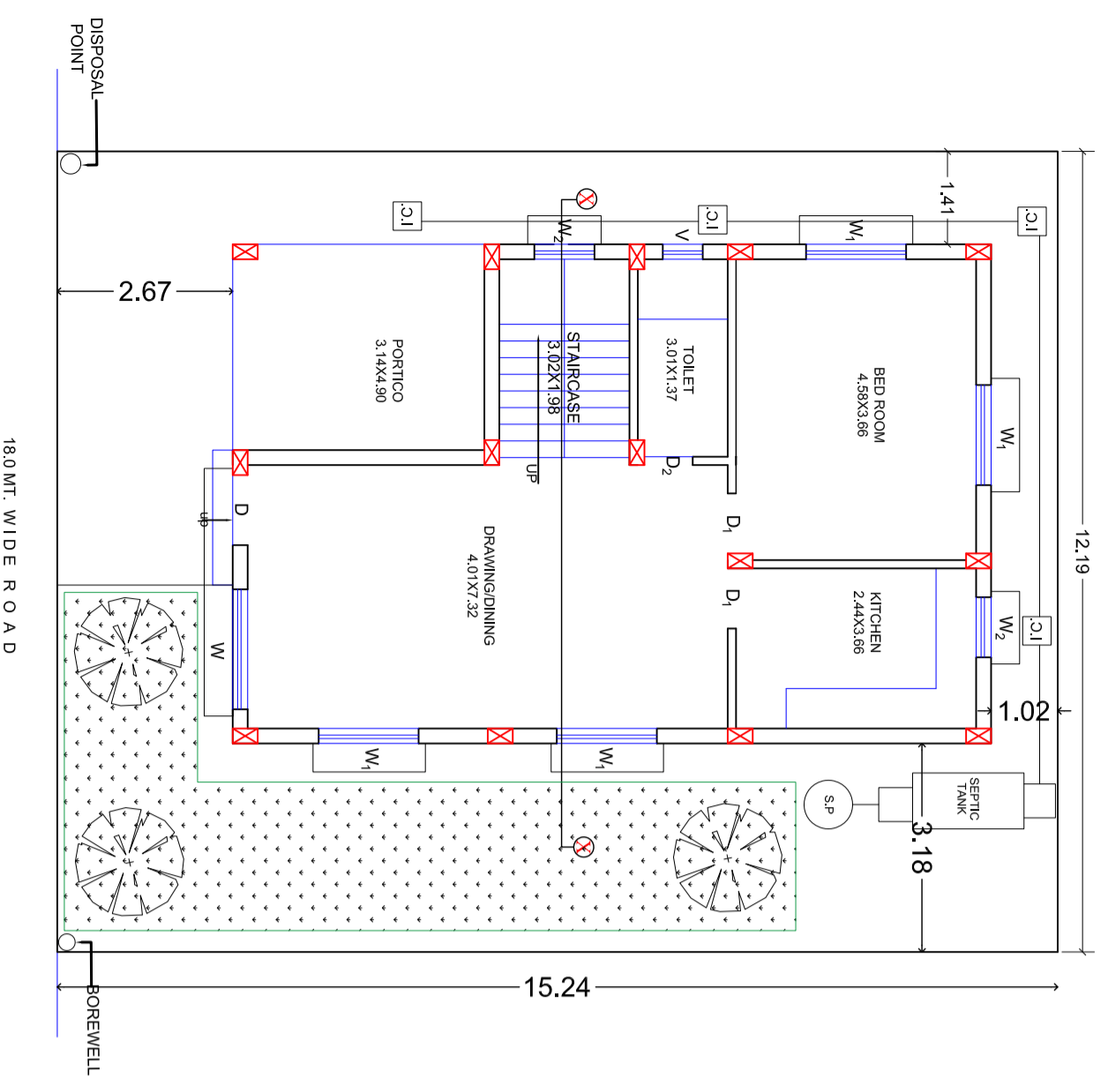

PRINT ON A2 SIZE PAPER

PRINT ON A2 SIZE PAPER

PRINT ON A2 SIZE PAPER

DRAWING TITLE  
**PROPOSED G+1 STOREIED RESIDENTIAL HOUSE**  
THIS IS A STANDARDIZED PRE-APPROVED PLAN PROVIDED BY

