

Pre-Approved Building Plan No
40500908

SANCTION TEXT

APPROVING AUTHORITY DIGITAL SIGNATURE

DOOR & WINDOW SCHEDULE		
SL. NO.	TYPE	DESCRIPTION
1	D	1.07 X 2.13 PANELLED DOOR
2	D1	0.91 X 2.13 PANELLED DOOR
3	D2	0.76 X 2.13 PANELLED DOOR
4	W	1.52 X 1.37 MS. GLAZED WINDOW
5	W1	0.91 X 1.37 MS. GLAZED WINDOW
6	W2	1.22 X 1.14 MS. GLAZED WINDOW
7	V	0.61 X 0.61 MS. GLAZED VENTILATOR

AREA AND BUILDING PARAMETERS	
PLOT DIMENSIONS (IN FEET)	40' X 50'
PLOT DIMENSIONS (IN MT)	12.19M X 15.24M
PLOT AREA	185.87 SQMT
GROUND FLOOR BUILT UP AREA	120.81 SQMT
FIRST FLOOR BUILT UP AREA	120.81 SQMT
TOTAL BUILT UP AREA	241.63 SQMT
FLOOR AREA RATIO (FAR)	1.29
BUILDING HEIGHT	6.40 MT
PLANTATION AREA	46.42 SQMT
NUMBER OF TREES PROVIDED	03 NOS

APPLICANT DETAILS	
NAME OF APPLICANT	
ADDRESS	
CONTACT NUMBER	

LAND DETAILS	
REVENUE VILLAGE	
REVENUE PLOT NO	
SCHEME PLOT NO./LAYOUT PLOT NO./SUB PLOT NO	
KHATA NUMBER	

SITE PLAN

DRAWING TITLE
PROPOSED G+1 STOREIED RESIDENTIAL HOUSE
THIS IS A STANDARDIZED PRE-APPROVED PLAN PROVIDED BY

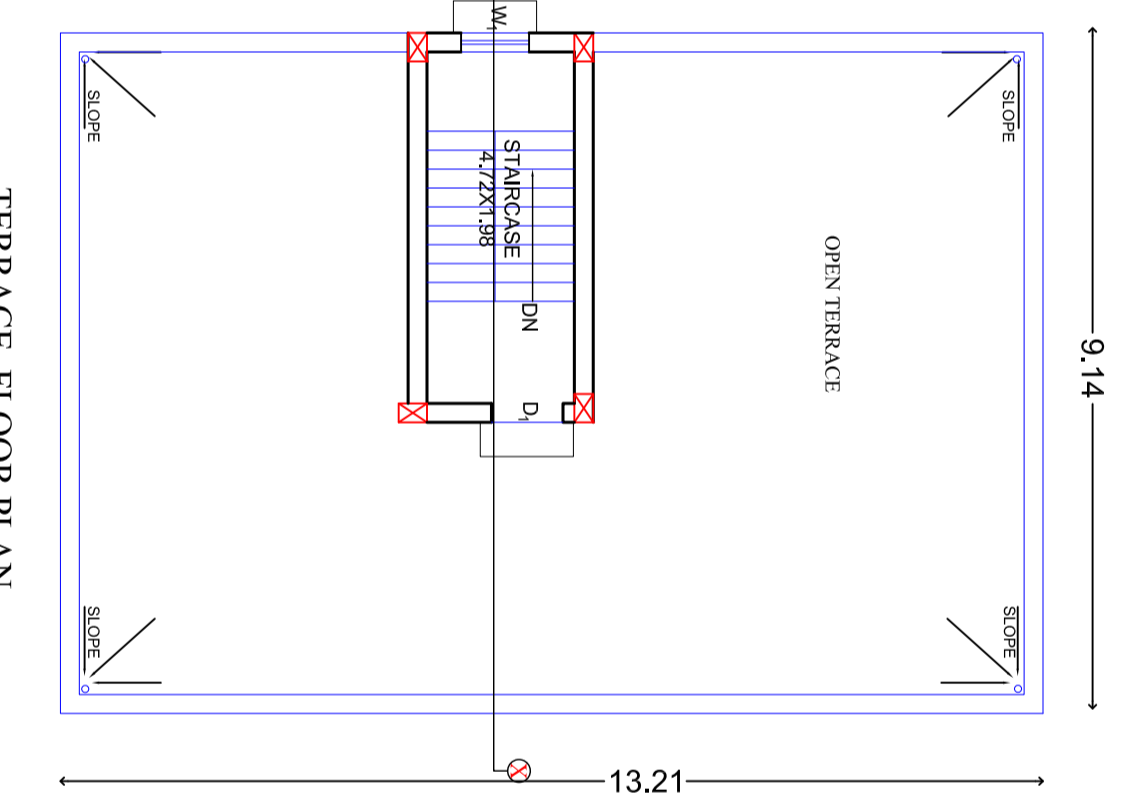
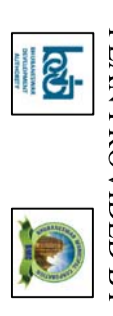

TERRACE FLOOR PLAN

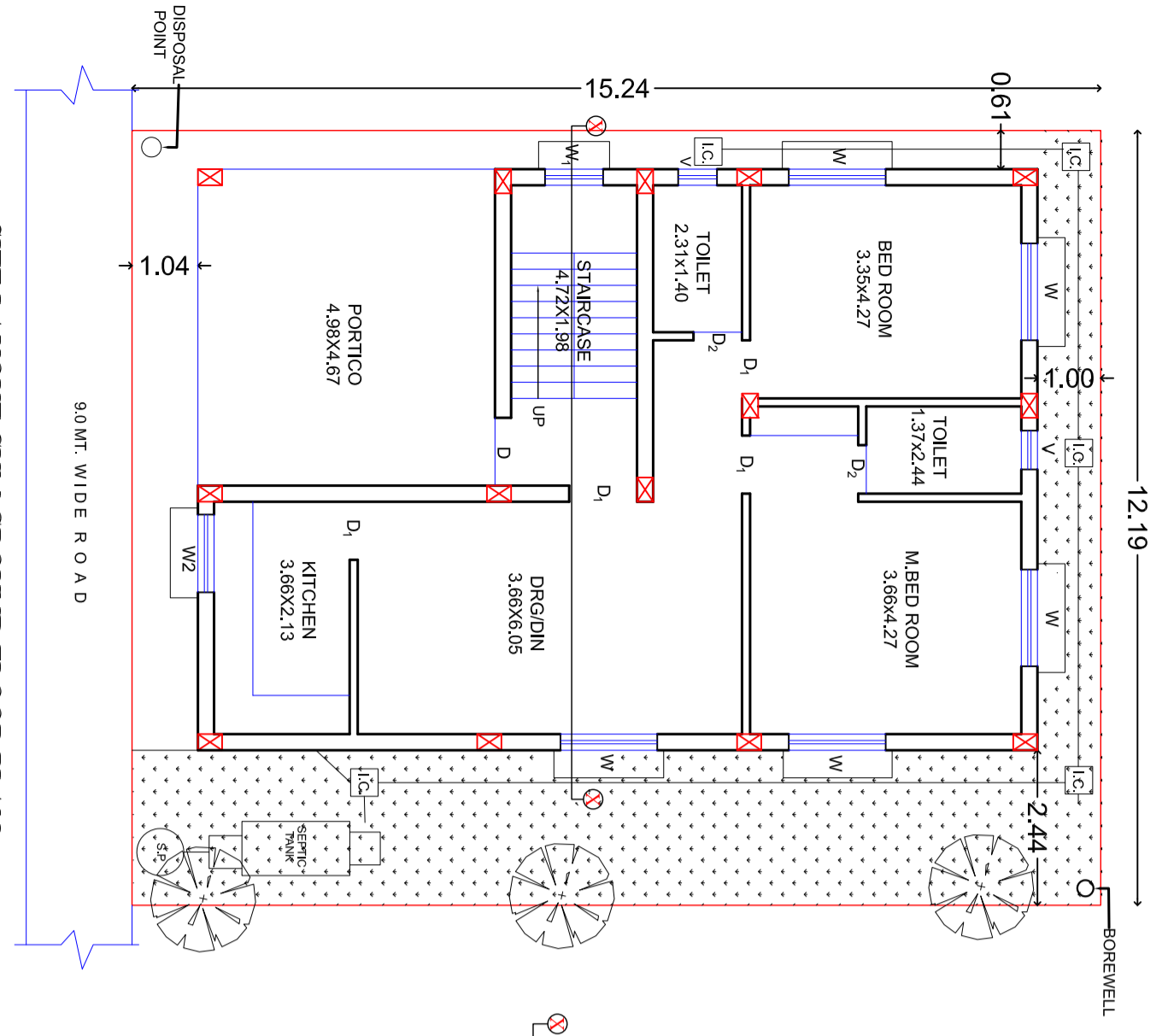

SITE LAYOUT CUM GROUND FLOOR PLAN

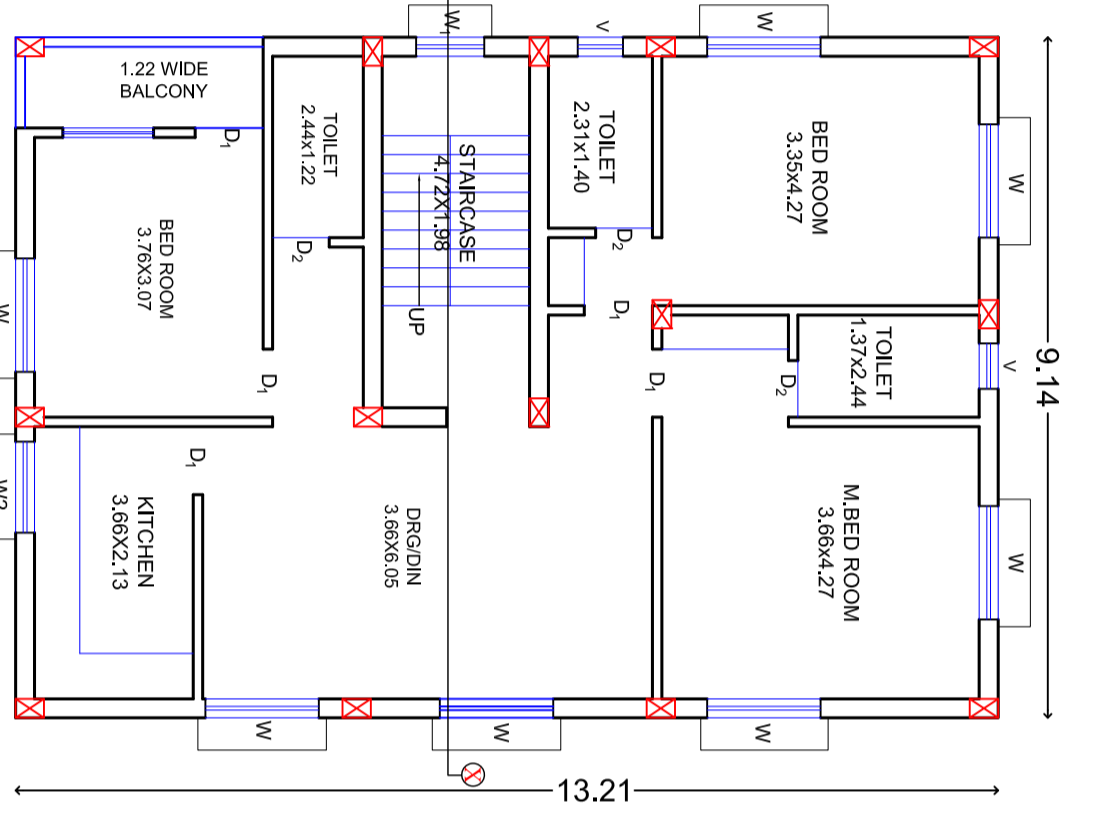

FIRST FLOOR PLAN

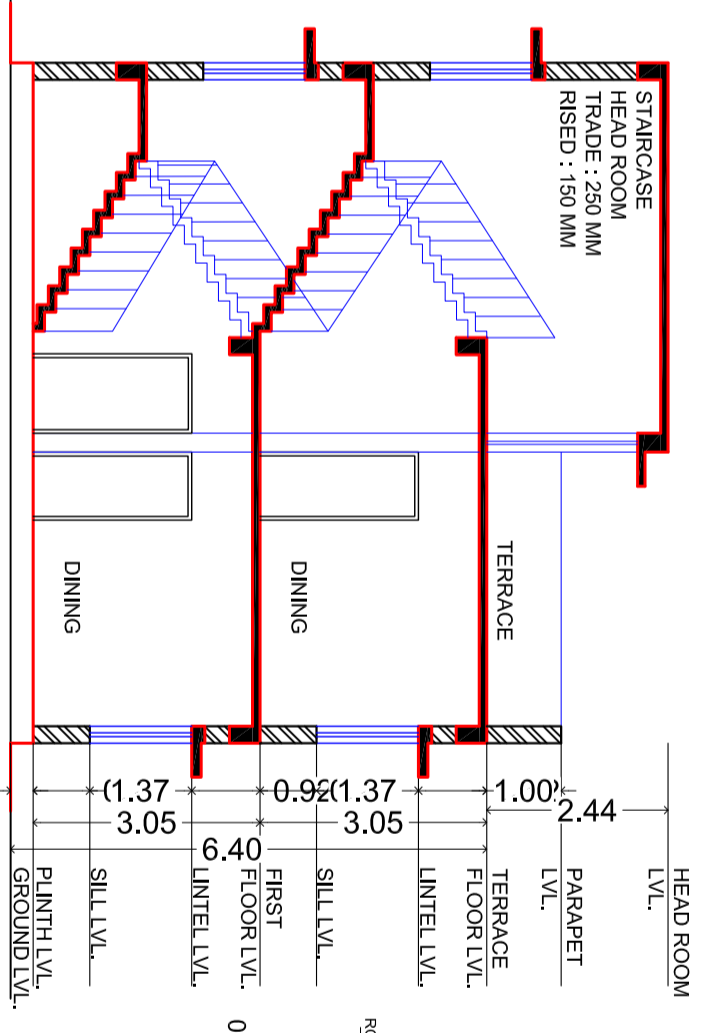

SECTION AT X-X

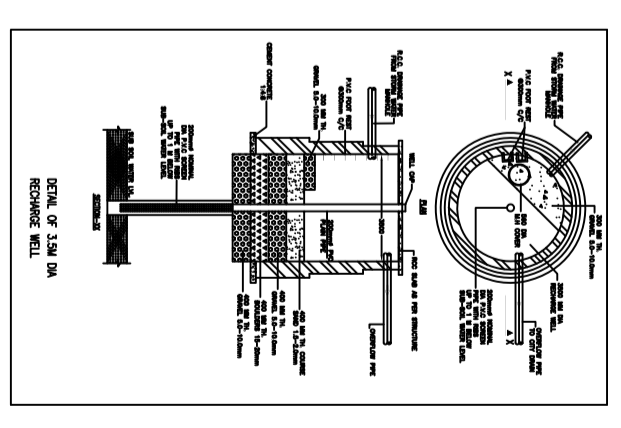

WALL FOUNDATION

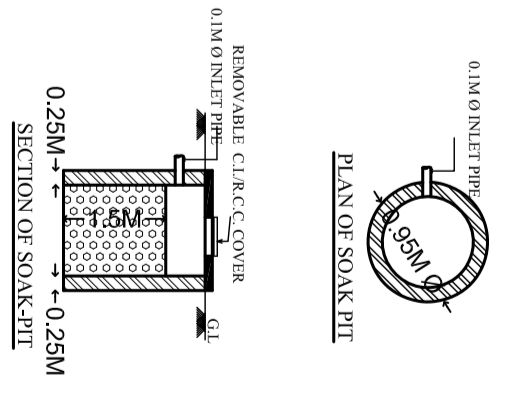

PLAN OF SOAK PIT

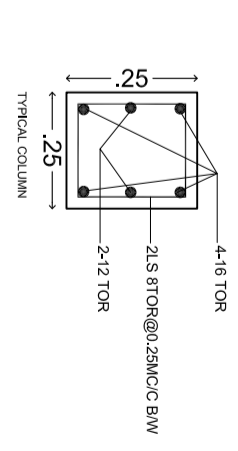

TYPICAL COLUMN

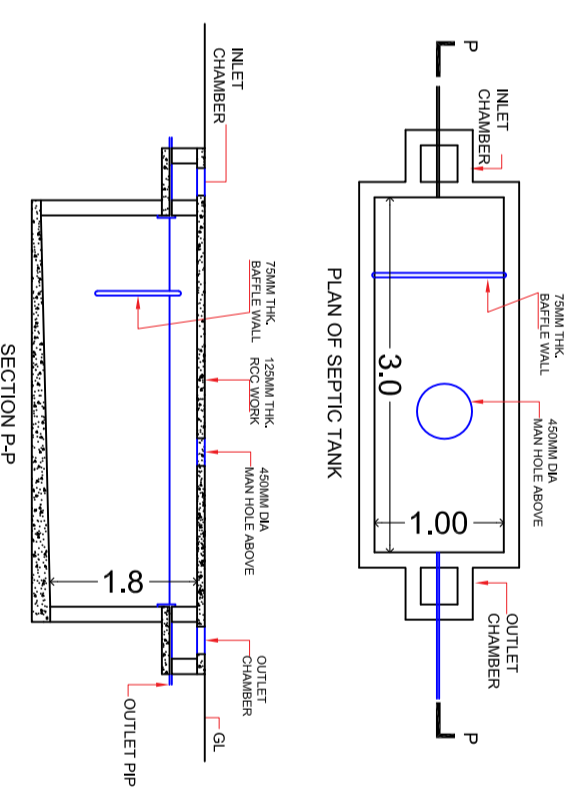

PLAN OF SEPTIC TANK

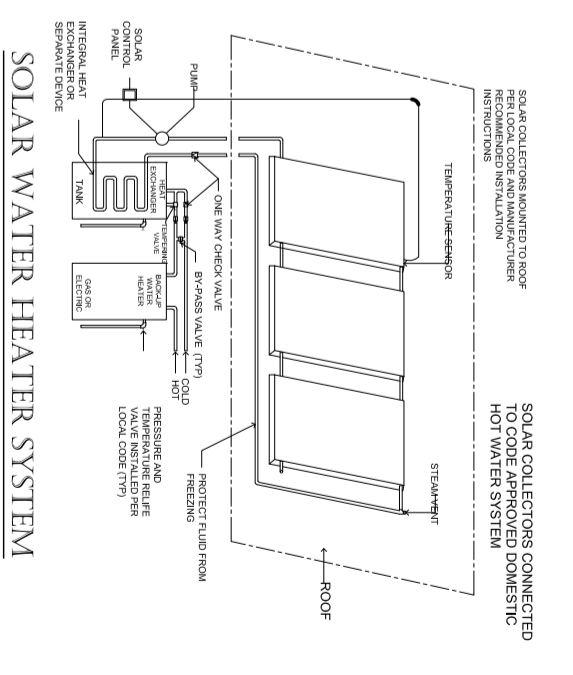

SOLAR WATER HEATER SYSTEM

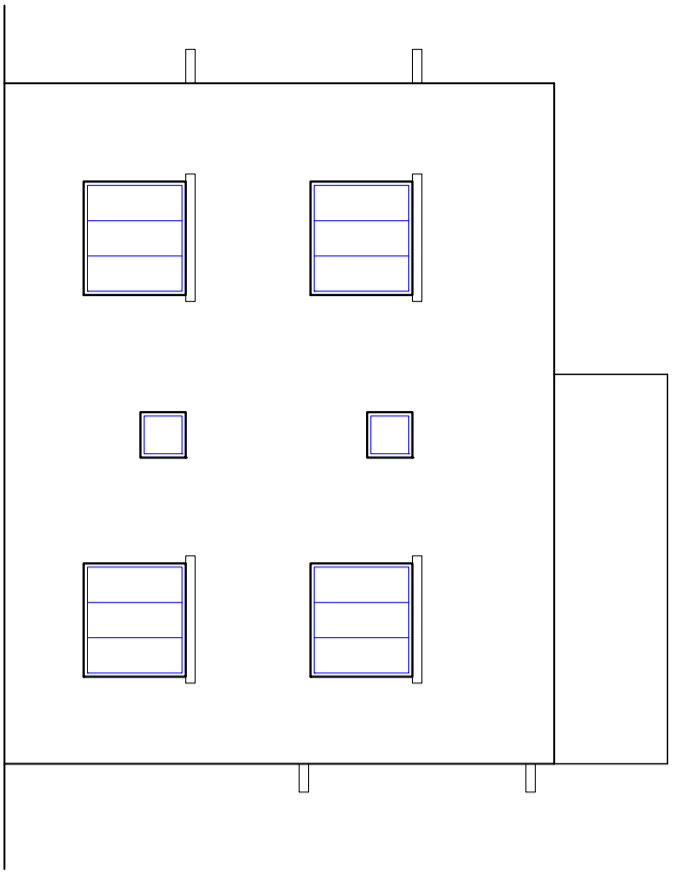

FRONT ELEVATION

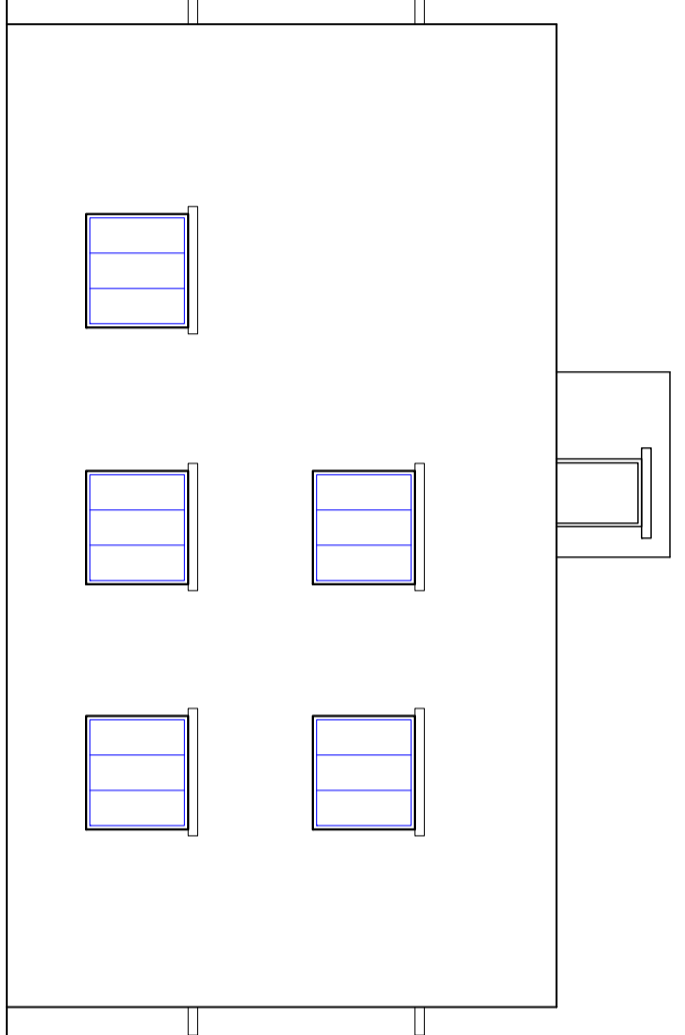

RIGHT SIDE ELEVATION

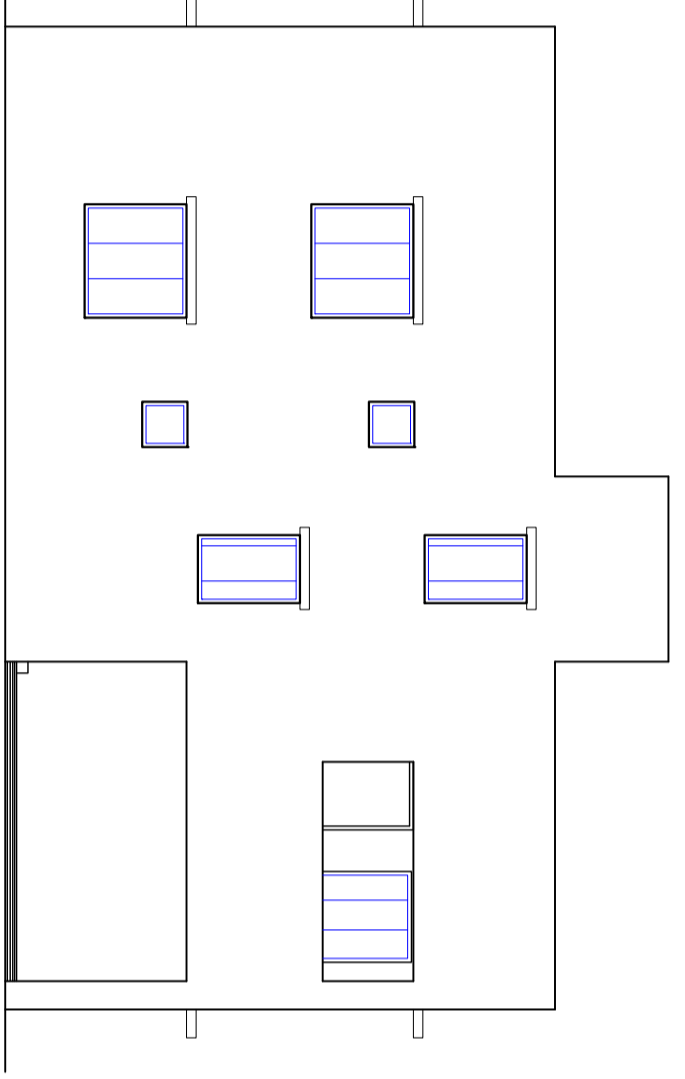

LEFT SIDE ELEVATION

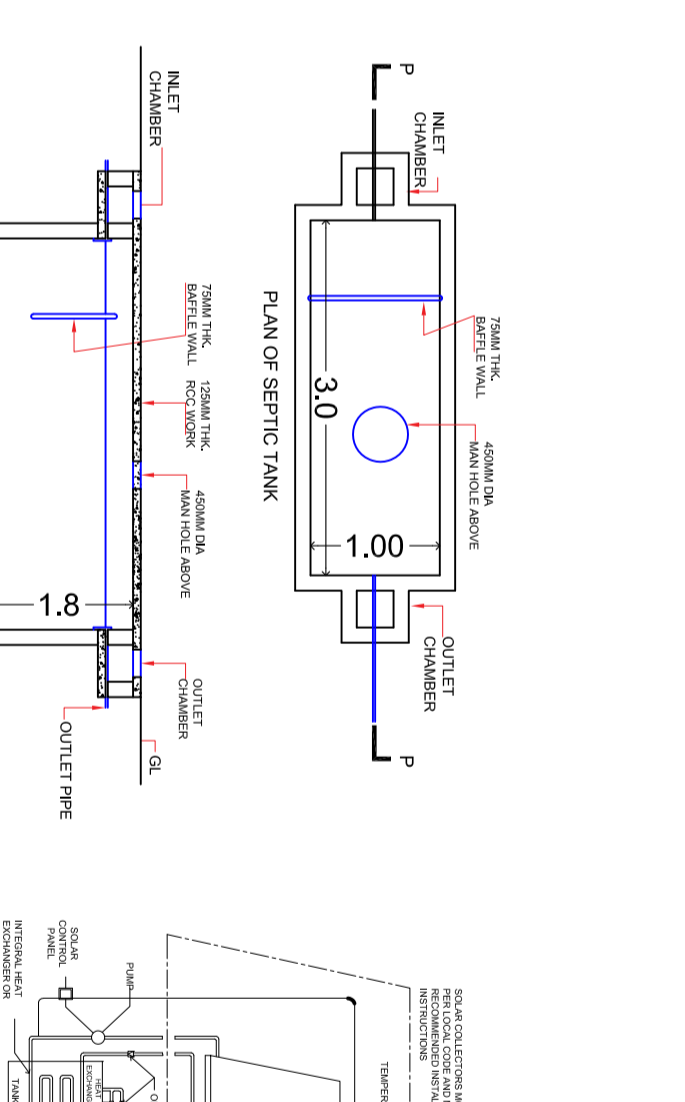

REAR ELEVATION