

SANCTION TEXT

APPROVING AUTHORITY DIGITAL SIGNATURE

DOOR & WINDOW SCHEDULE

S/L NO.	TYPE	SIZE	DESCRIPTION
1	D	1.00 X 2.10	PANELLED DOOR
2	D1	0.90 X 2.10	PANELLED DOOR
3	W	1.35 X 1.50	MS. GLAZED WINDOW
4	W1	2.00 X 1.50	MS. GLAZED WINDOW
5	V	0.80 X 0.80	MS. GLAZED VENTILATOR

AREA AND BUILDING PARAMETERS

PLOT DIMENSIONS (IN FEET)	30' x 50'
PLOT DIMENSIONS (IN MT)	9.14M x 15.24M
PLOT AREA	139.29 SQMT
GROUND FLOOR BUILT UP AREA	84.69 SQMT
FIRST FLOOR BUILT UP AREA	84.69 SQMT
SECOND FLOOR BUILT UP AREA	70.96 SQMT
TOTAL BUILT UP AREA	240.34 SQMT
FLOOR AREA RATIO (FAR)	1.72
BUILDING HEIGHT	9.30 MT
PLANTATION AREA	0 SQMT
NUMBER OF TREES PROVIDED	2 NOS.

APPLICANT DETAILS

NAME OF APPLICANT	
ADDRESS	
CONTACT NUMBER	

LAND DETAILS

REVENUE VILLAGE	
REVENUE PLOT NO	
SCHEME PLOT NO./LAYOUT	
PLOT NO./ SUB PLOT NO	
KHATA NUMBER	

SITE PLAN

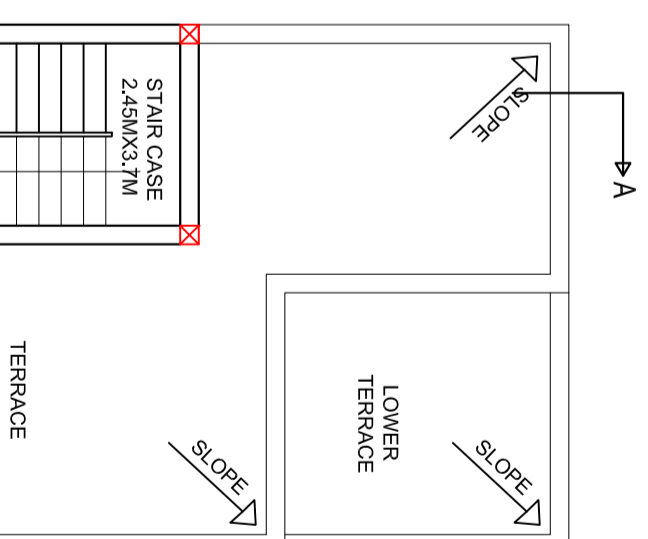

DRAWING TITLE

## PROPOSED G+2 STOREIED RESIDENTIAL HOUSE

THIS IS A STANDARDIZED PRE-APPROVED PLAN PROVIDED BY

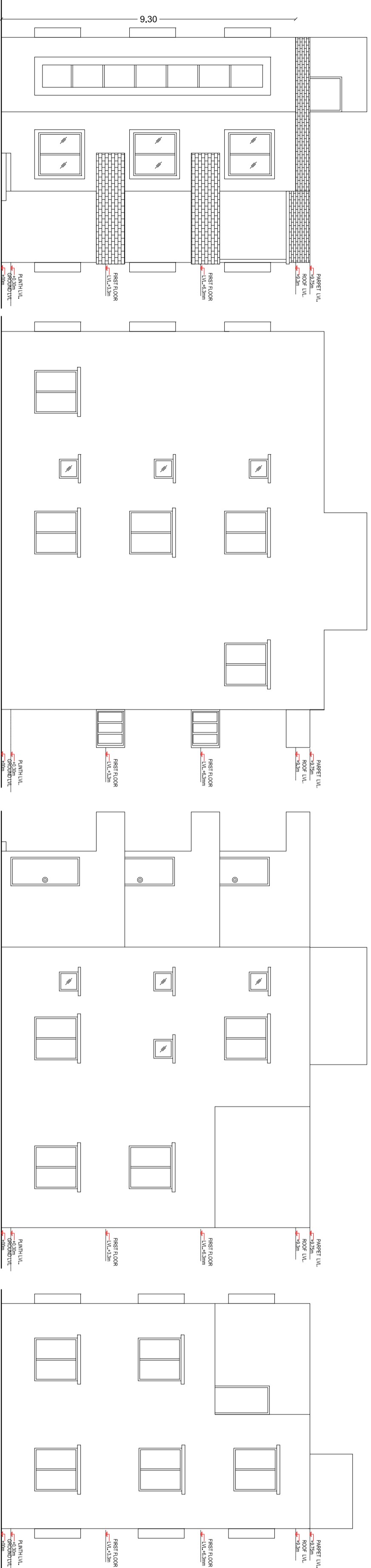

FRONT ELEVATION

LEFT SIDE ELEVATION

RIGHT SIDE ELEVATION

REAR ELEVATION

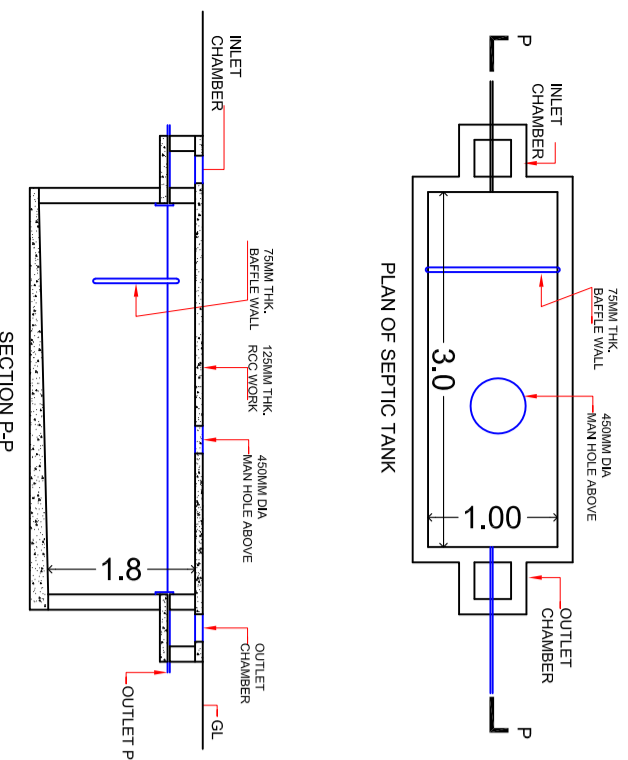

PLAN OF SEPTIC TANK

SECTION P-P

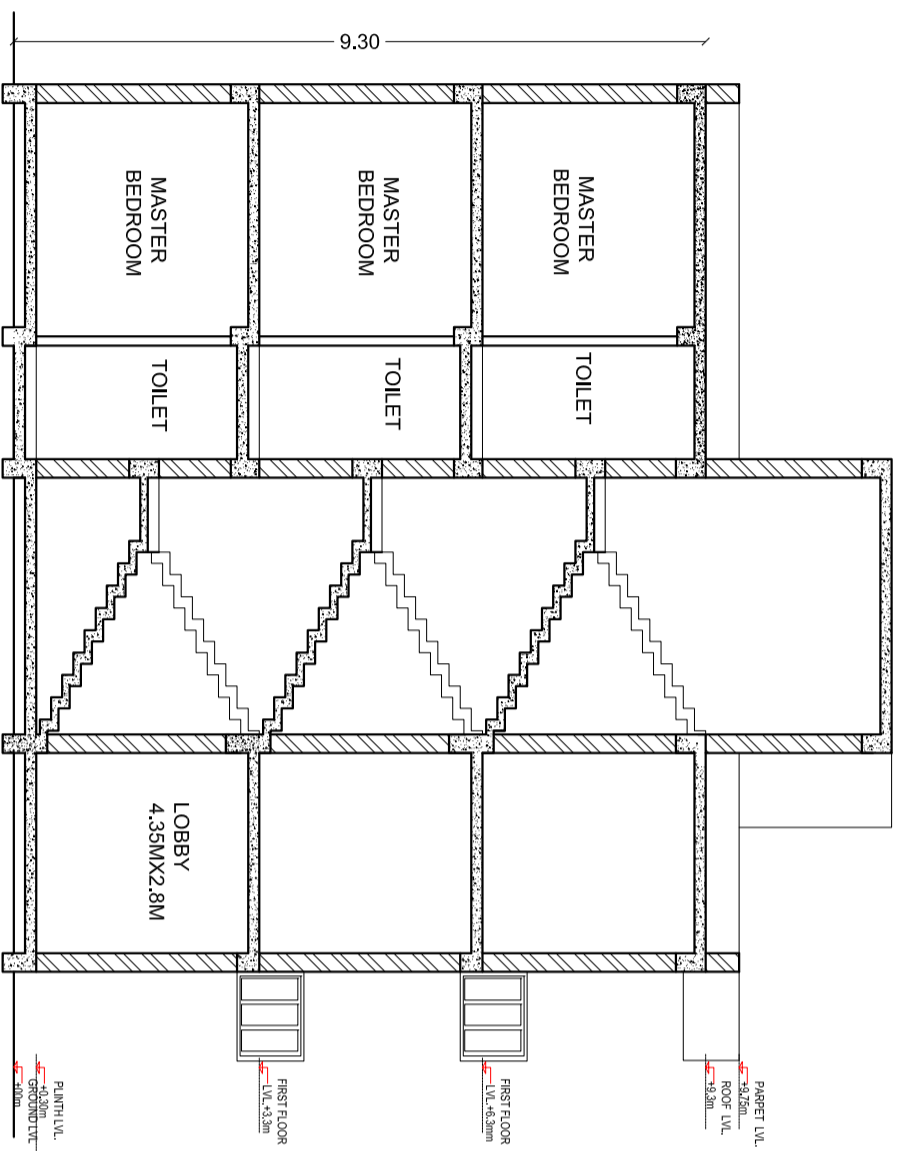

SECTION AT A-A'

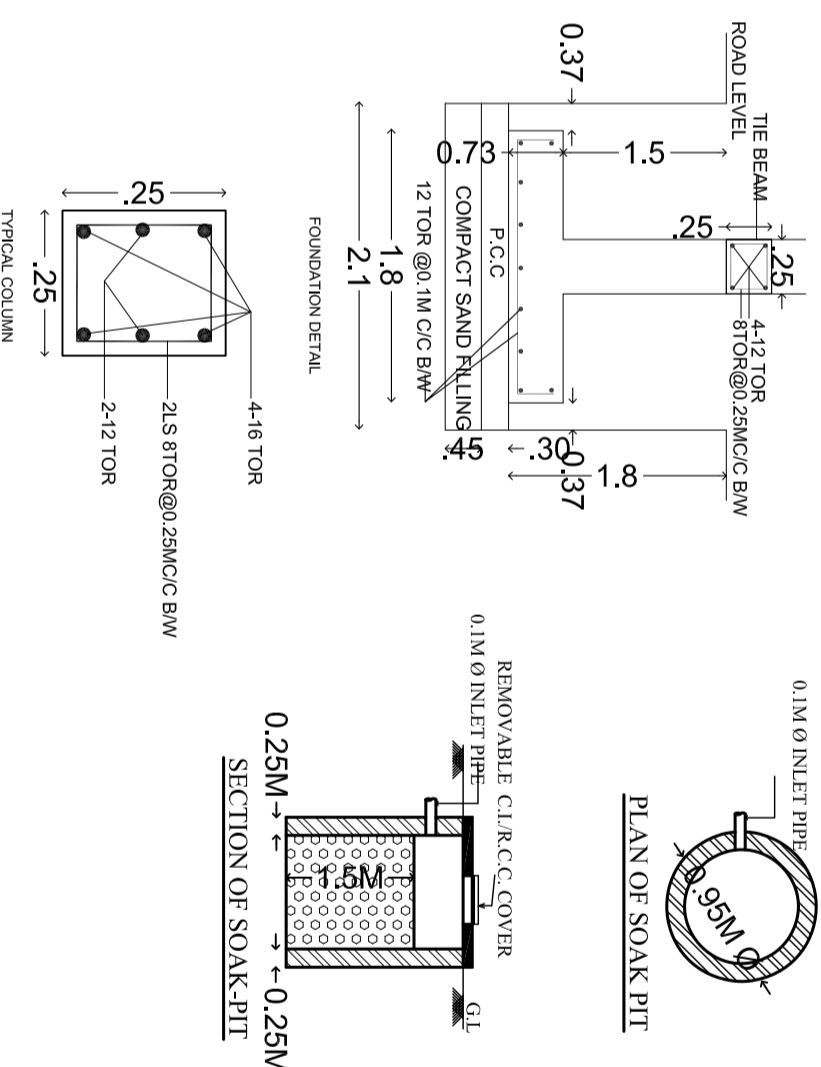

TYPICAL COLUMN

SECTION OF SOAK-PIT

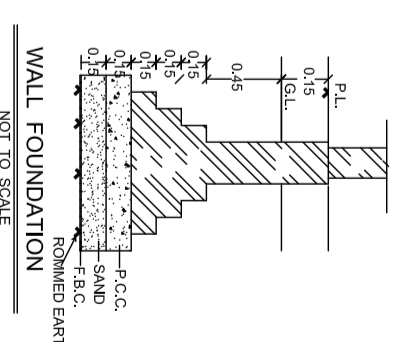

WALL FOUNDATION

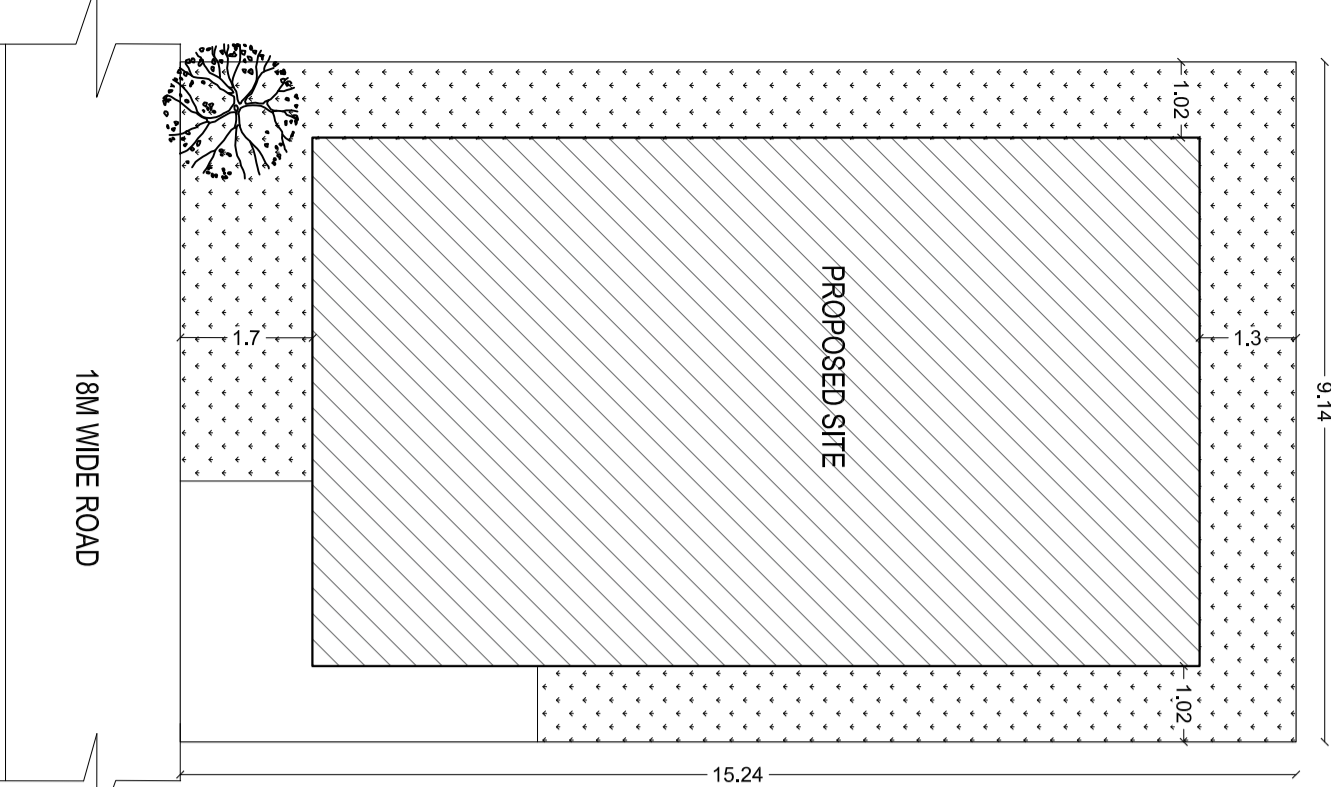

PROPOSED SITE

SITE PLAN

GROUND FLOOR PLAN

FIRST FLOOR PLAN

SECOND FLOOR PLAN

A' TERRACE PLAN