

SANCTION TEXT

APPROVING AUTHORITY DIGITAL SIGNATURE

DOOR & WINDOW SCHEDULE

S.L. NO.	TYPE	SIZE	DESCRIPTION
1	D	1.07 X 2.13	PANELLED DOOR
2	D1	0.91 X 2.13	PANELLED DOOR
3	D2	0.76 X 2.13	PANELLED DOOR
4	W	1.52 X 1.37	MS. GLAZED WINDOW
5	W1	0.91 X 1.37	MS. GLAZED WINDOW
6	W2	1.22 X 1.14	MS. GLAZED WINDOW
7	V	0.61 X 0.61	MS. GLAZED VENTILATOR

AREA AND BUILDING PARAMETERS

PLOT DIMENSIONS (IN FEET)	30' X 50'
PLOT DIMENSIONS (IN MT)	9.14M X 15.24M
PLOT AREA	139.38 SQMT
GROUND FLOOR BUILT UP AREA	89.88 SQMT
FIRST FLOOR BUILT UP AREA	89.88 SQMT
TOTAL BUILT UP AREA	179.76 SQMT
FLOOR AREA RATIO (FAR)	1.28
BUILDING HEIGHT	6.40 MT
PLANTATION AREA	35.78 SQMT
NUMBER OF TREES PROVIDED	02 NOS

APPLICANT DETAILS

NAME OF APPLICANT	
ADDRESS	
CONTACT NUMBER	

LAND DETAILS

REVENUE VILLAGE	
REVENUE PLOT NO	
SCHEME PLOT NO/LAYOUT	
PLOT NO./SUB PLOT NO	
KHATA NUMBER	

SITE PLAN

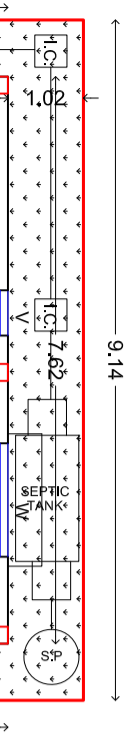

18 MT. WIDE ROAD

SITE LAYOUT cum GROUND FLOOR PLAN

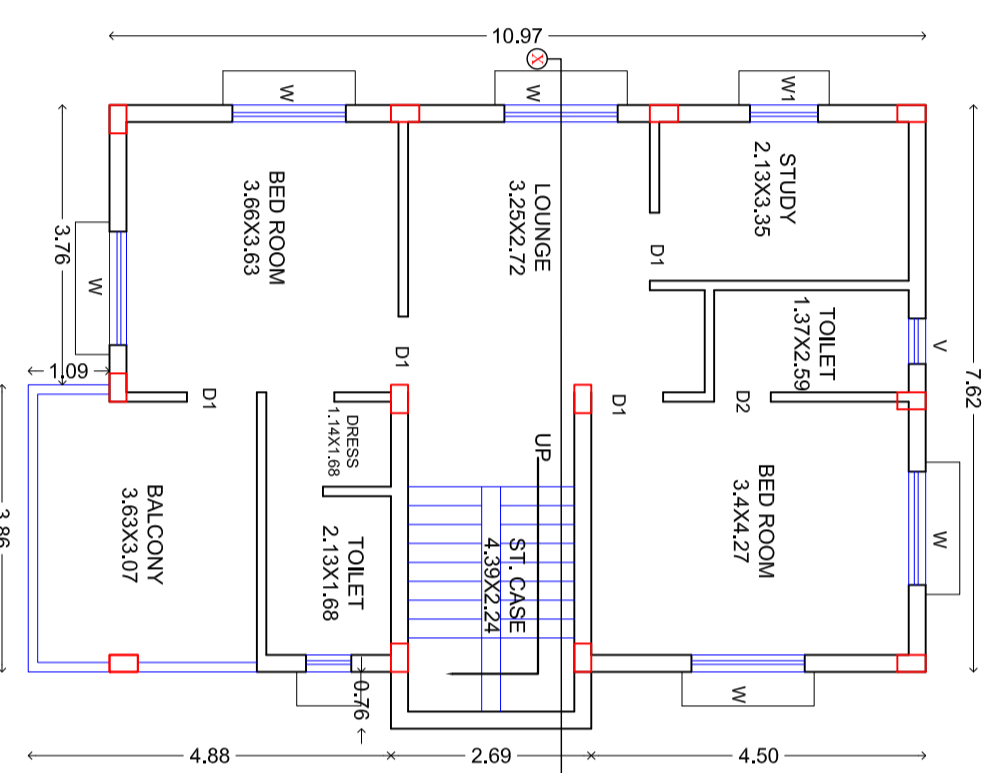

FIRST FLOOR PLAN

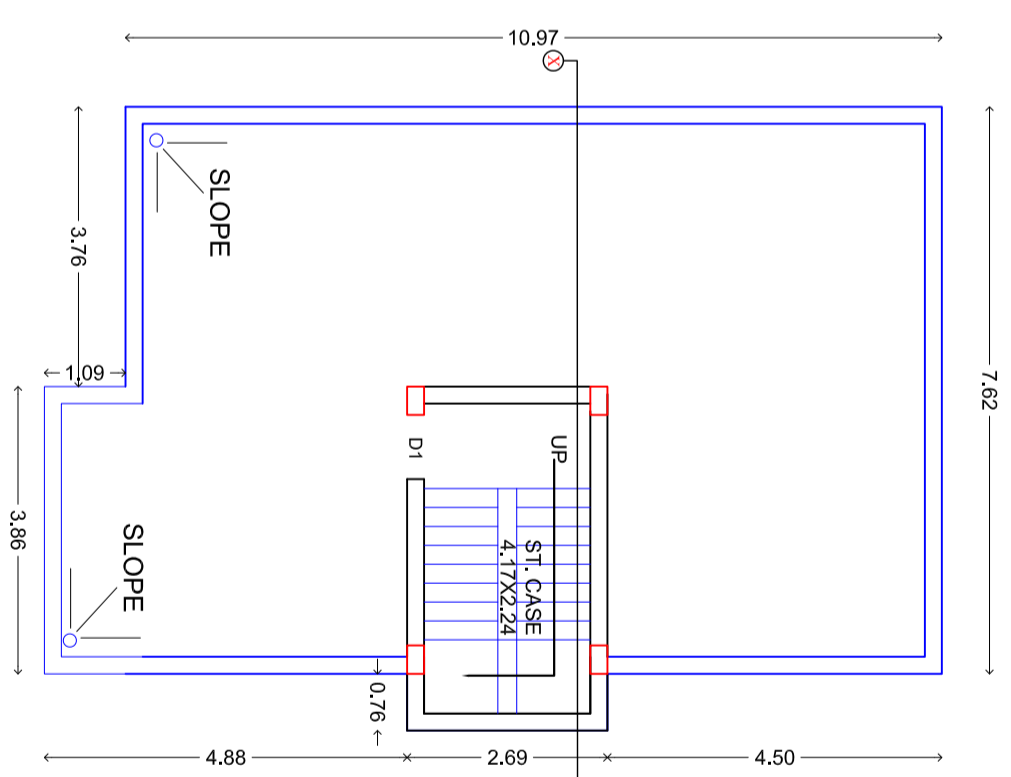

TERRACE FLOOR PLAN

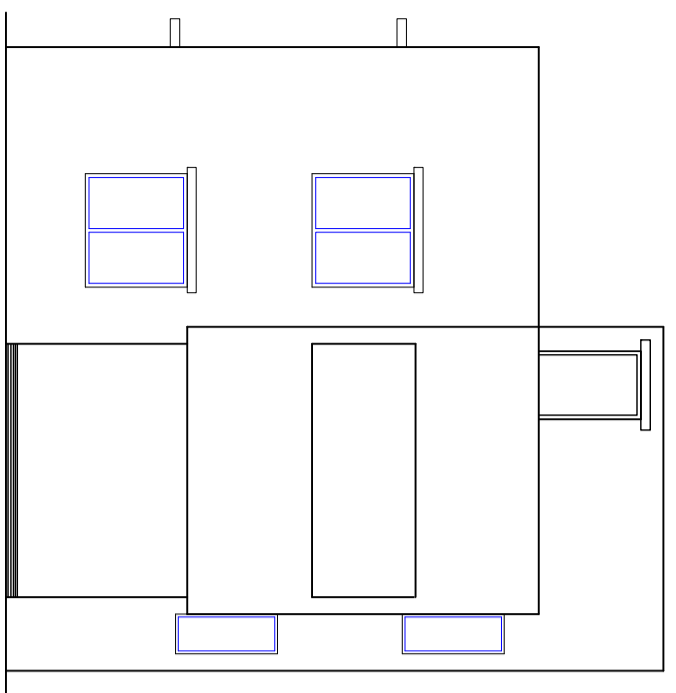

FRONT ELEVATION

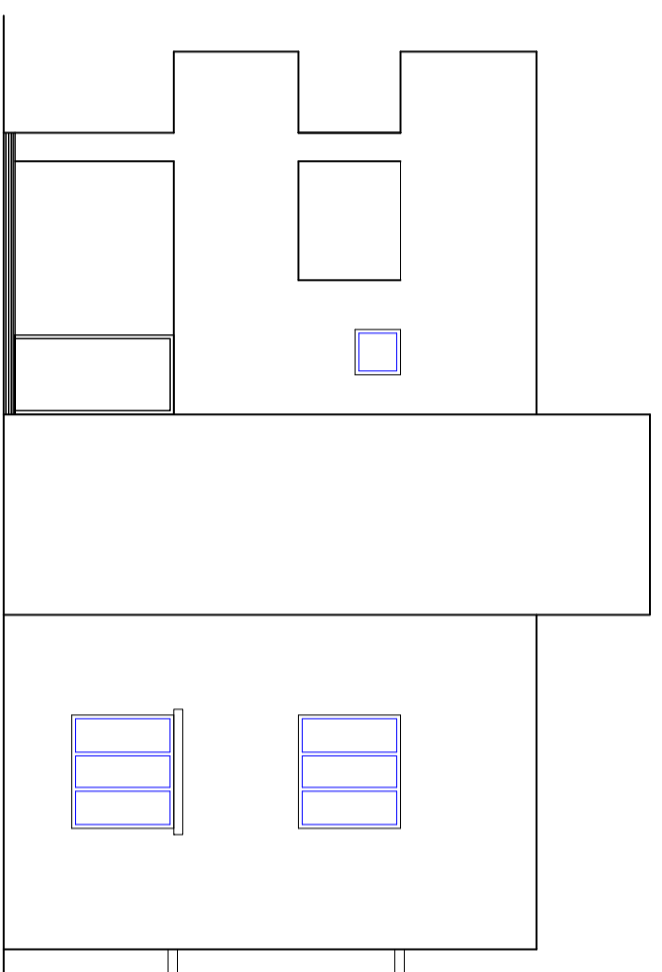

RIGHT SIDE ELEVATION

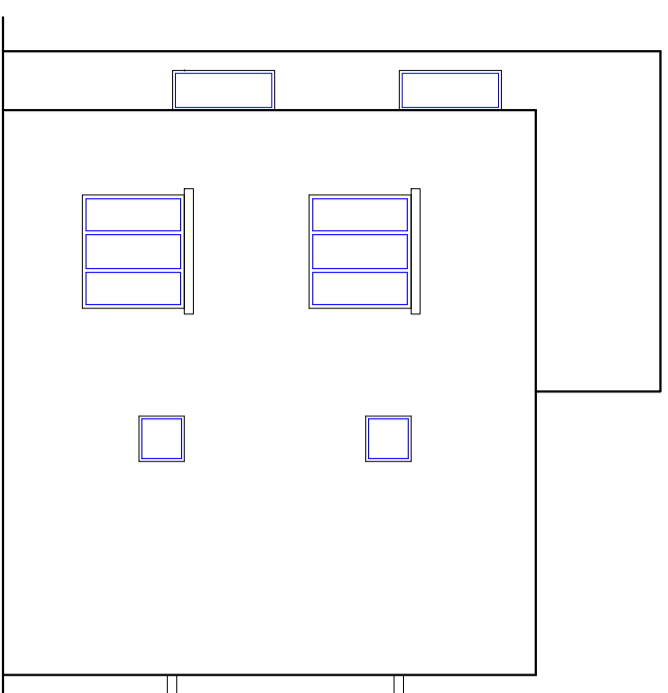

REAR ELEVATION

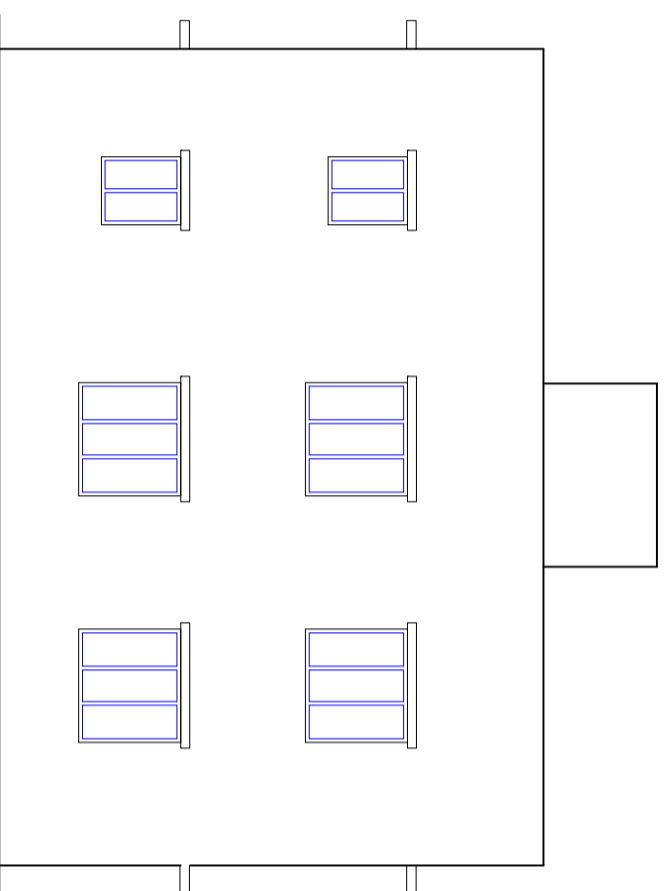

LEFT SIDE ELEVATION

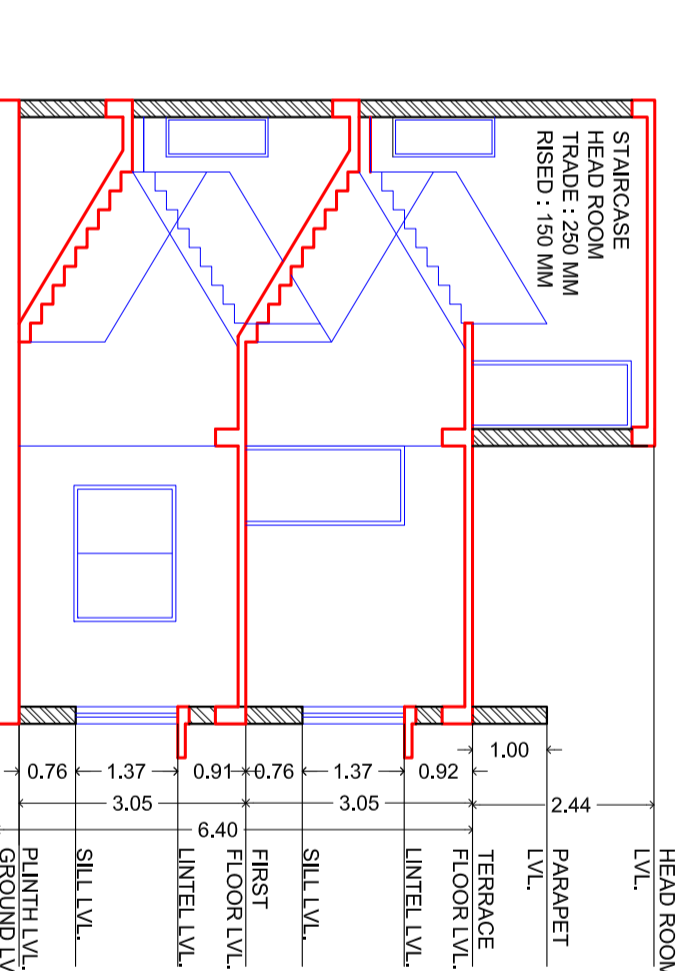

SECTION AT X-X

PLAN OF SOAK PIT

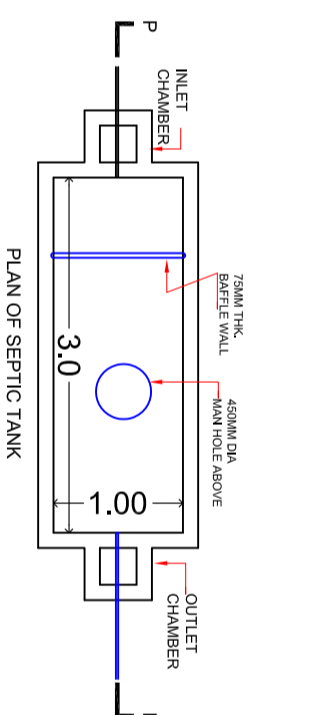
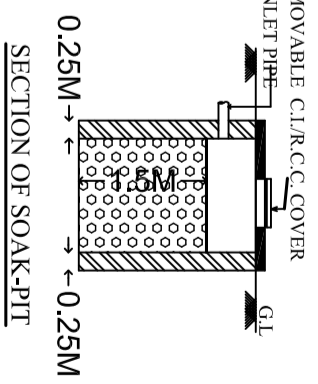

PLAN OF SEPTIC TANK

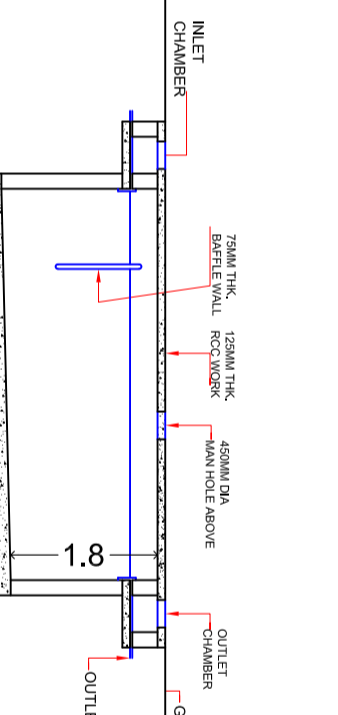

SECTION P-P

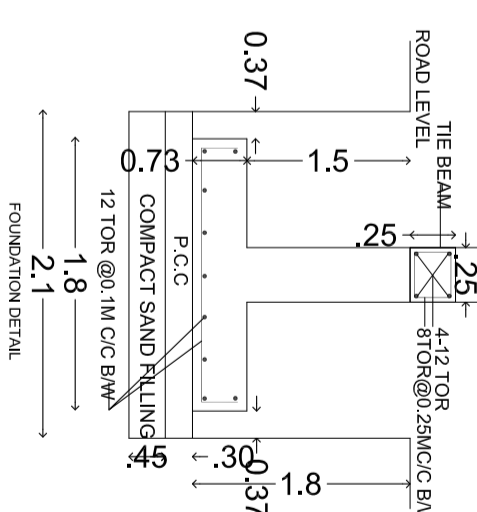

FOUNDATION DETAIL

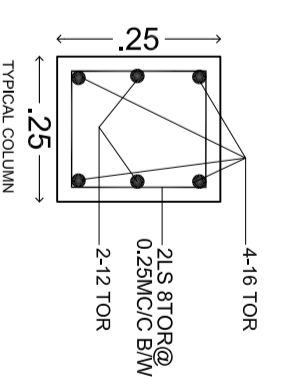

TYPICAL COLUMN

DETAILINGS

DRAWING-TITLE
**PROPOSED G+1 STORIED
 RESIDENTIAL HOUSE**

THIS IS A STANDARDIZED PRE-APPROVED
 PLAN PROVIDED BY

