

SANCTION TEXT

APPROVING AUTHORITY DIGITAL SIGNATURE

DOOR & WINDOW SCHEDULE		
S/L NO.	TYPE	DESCRIPTION
1	D	1.07 X 2.13 PANELLED DOOR
2	D1	0.91 X 2.13 PANELLED DOOR
3	D2	0.76 X 2.13 PANELLED DOOR
4	W	1.52 X 1.37 MS. GLAZED WINDOW
5	W1	0.91 X 1.37 MS. GLAZED WINDOW
6	W2	1.22 X 1.14 MS. GLAZED WINDOW
7	V	0.61 X 0.61 MS. GLAZED VENTILATOR

AREA AND BUILDING PARAMETERS		
PLOT DIMENSIONS (IN FEET)	30' X 50'	
PLOT DIMENSIONS (IN MT)	9.14M X 15.24M	
PLOT AREA	139.38 SQMT	
GROUND FLOOR BUILT UP AREA	89.88 SQMT	
FIRST FLOOR BUILT UP AREA	89.88 SQMT	
TOTAL BUILT UP AREA	179.76 SQMT	
FLOOR AREA RATIO (FAR)	1.28	
BUILDING HEIGHT	6.40 MT	
PLANTATION AREA	35.78 SQMT	
NUMBER OF TREES PROVIDED	02 NOS	

APPLICANT DETAILS	
NAME OF APPLICANT	
ADDRESS	
CONTACT NUMBER	

LAND DETAILS	
REVENUE VILLAGE	
REVENUE PLOT NO	
SCHEME PLOT NO./LAYOUT	
PLOT NO./SUB PLOT NO	
KHATA NUMBER	

SITE PLAN

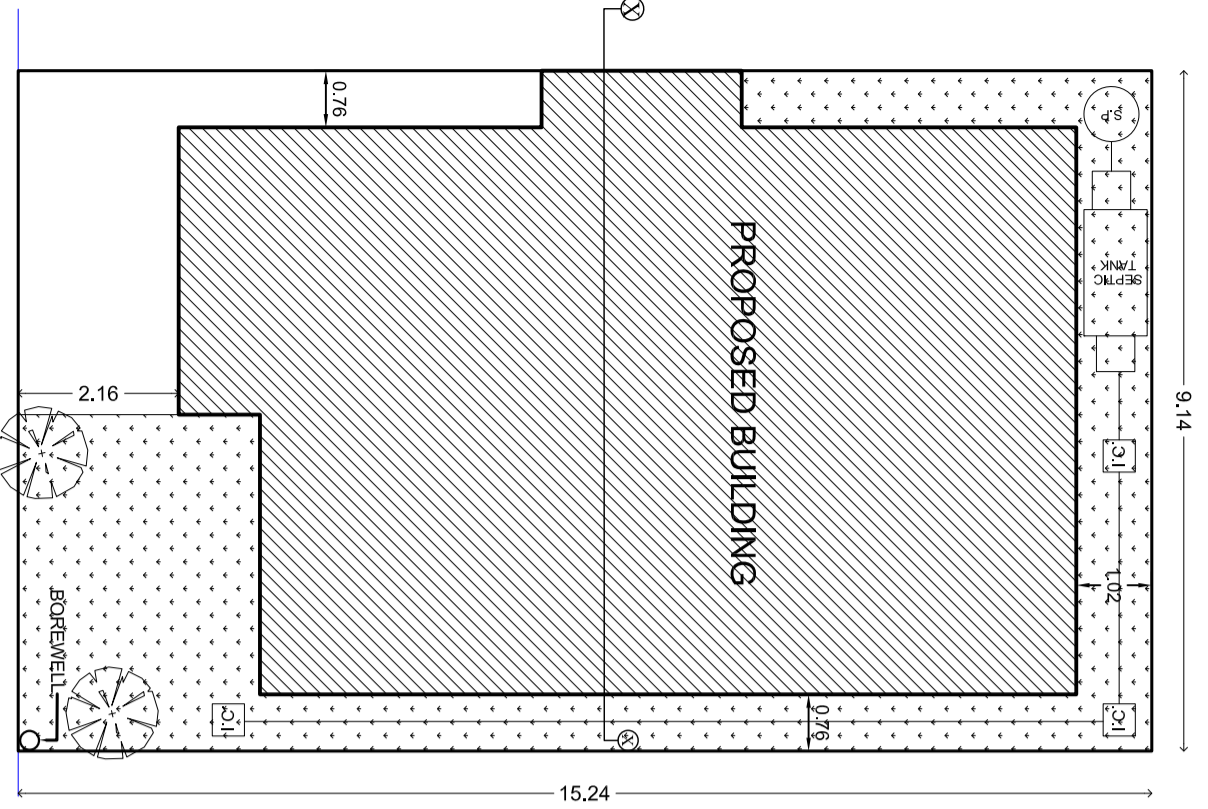
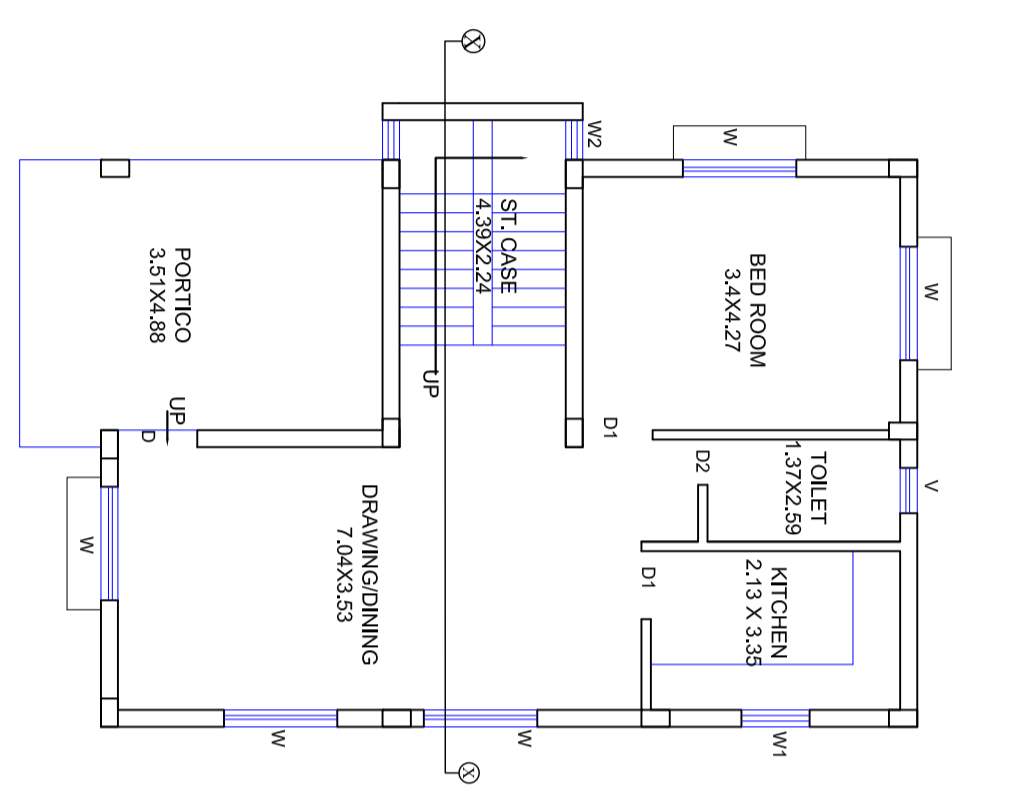
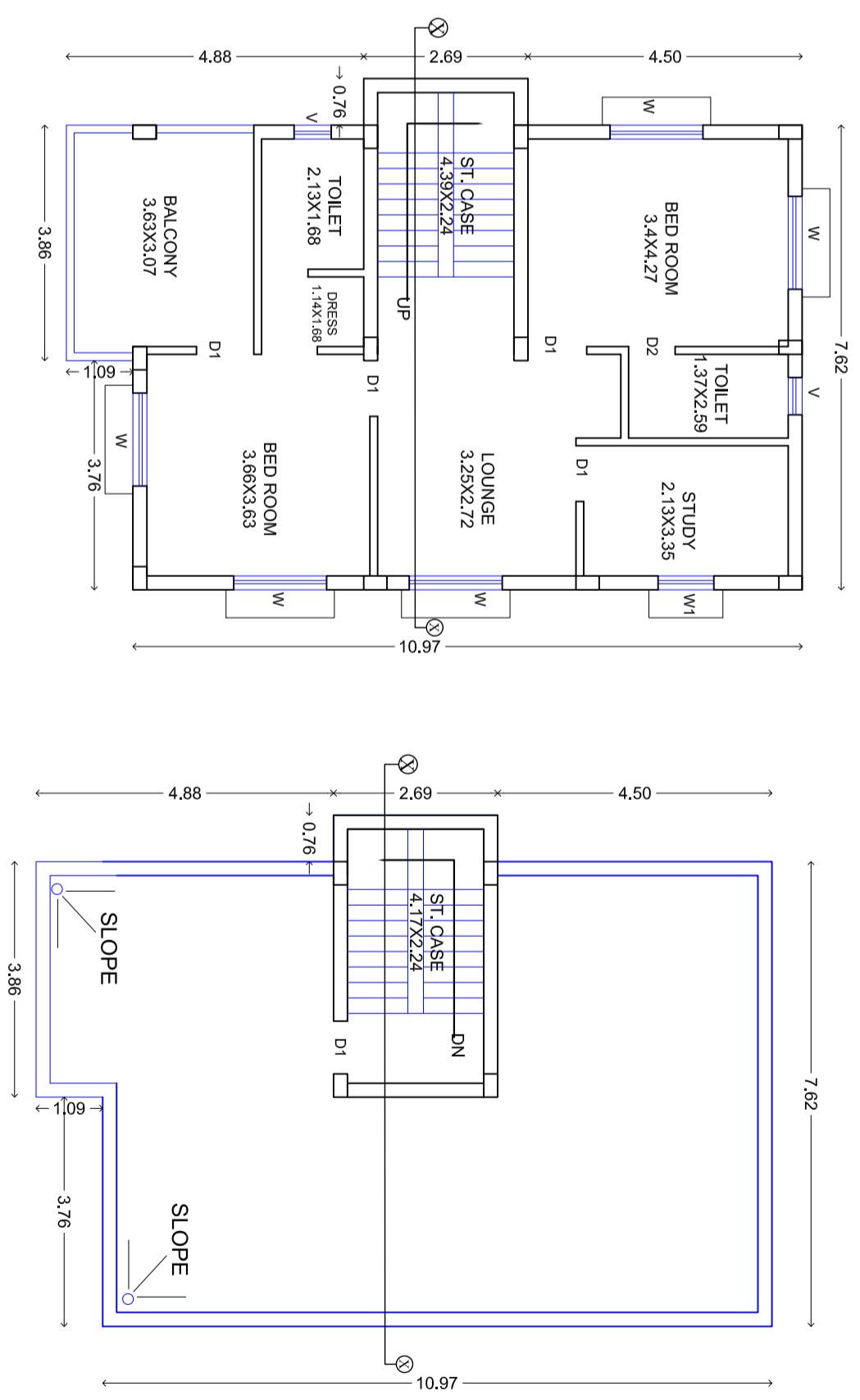

GROUND FLOOR PLAN

FIRST FLOOR PLAN

TERRACE FLOOR PLAN

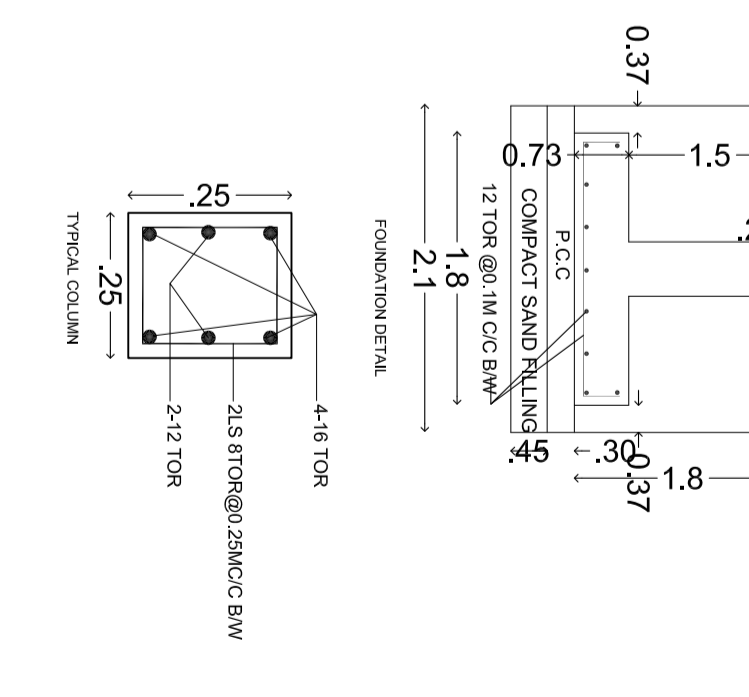
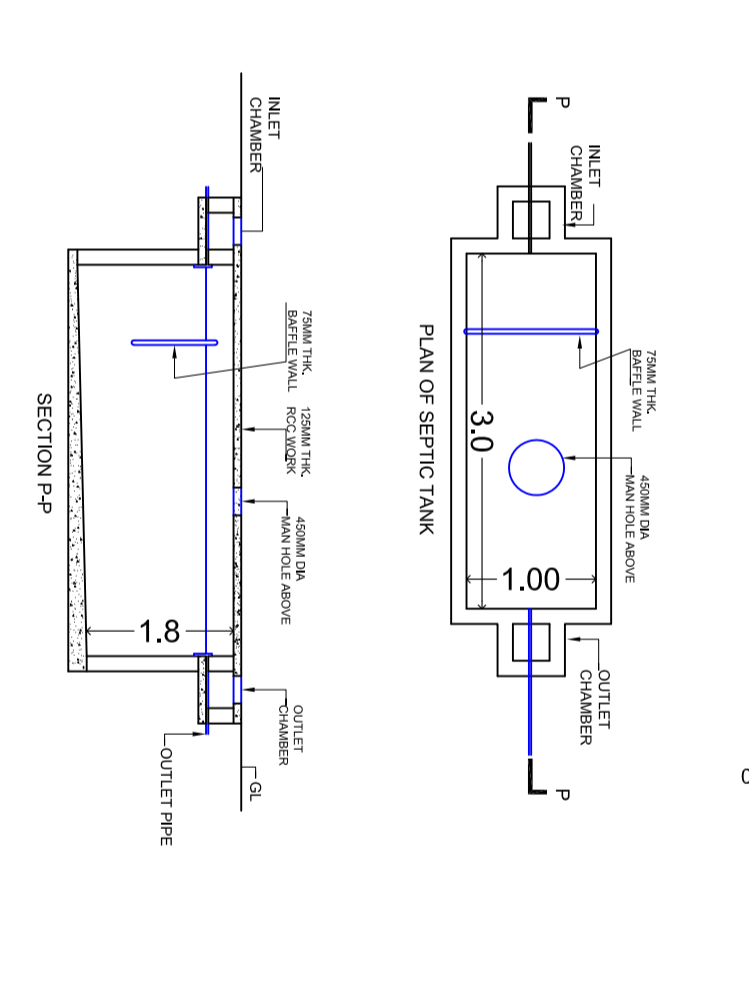
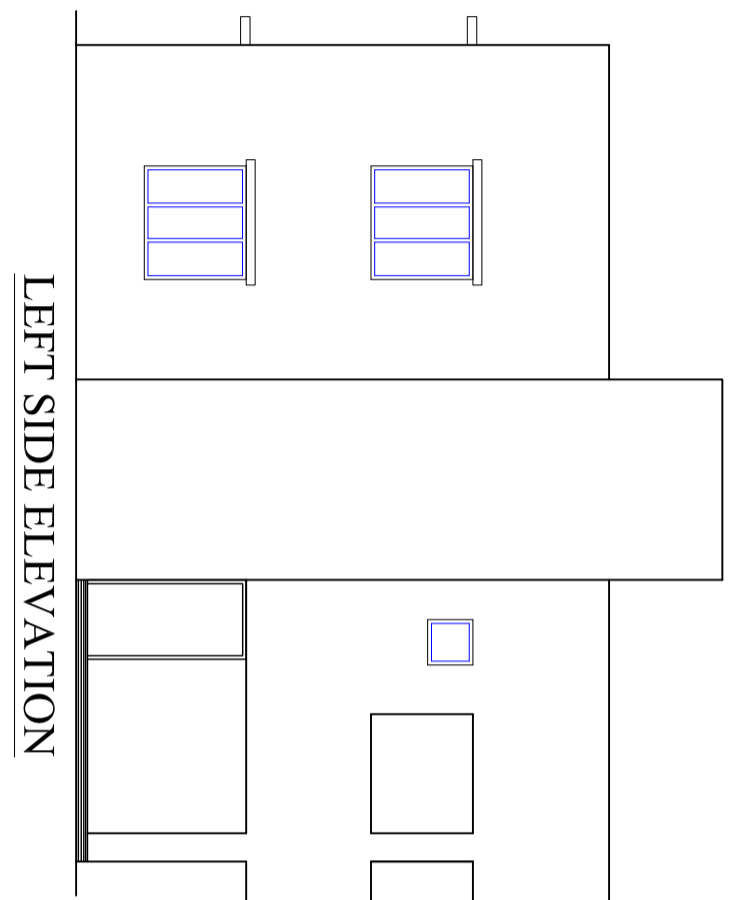
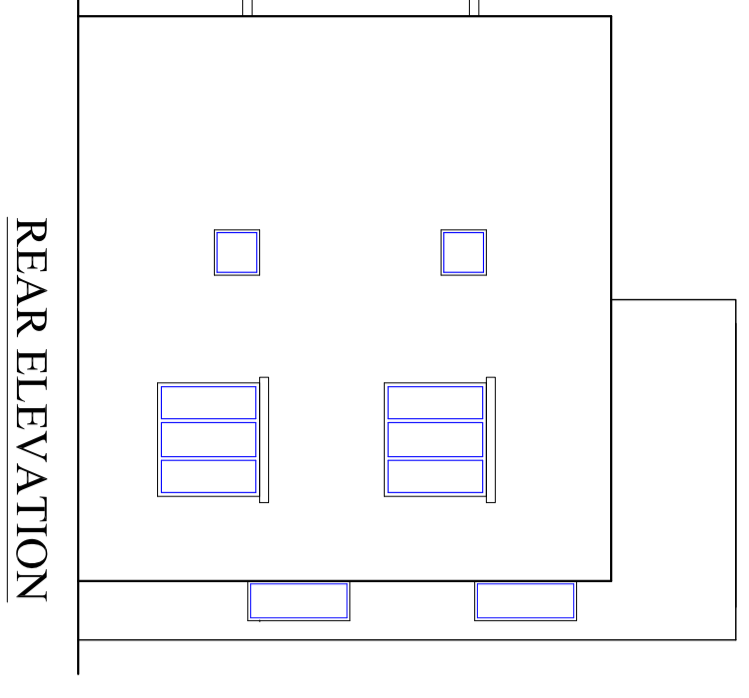
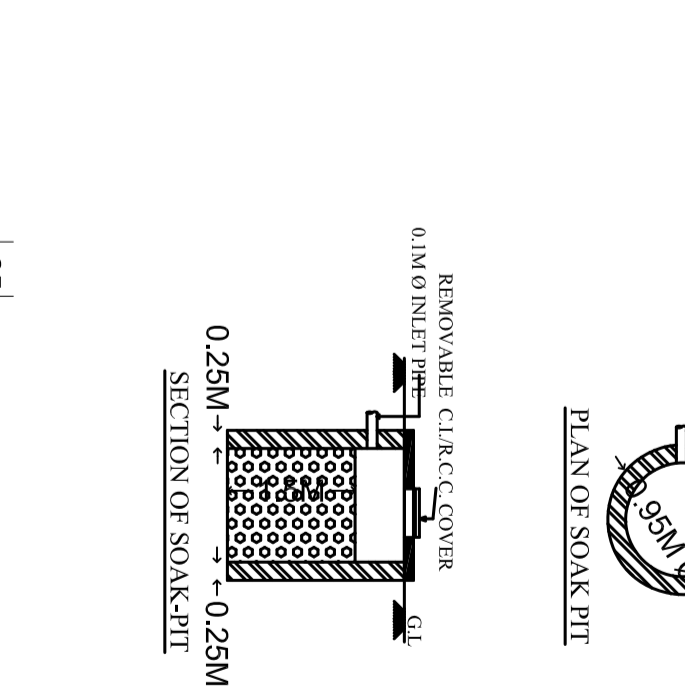
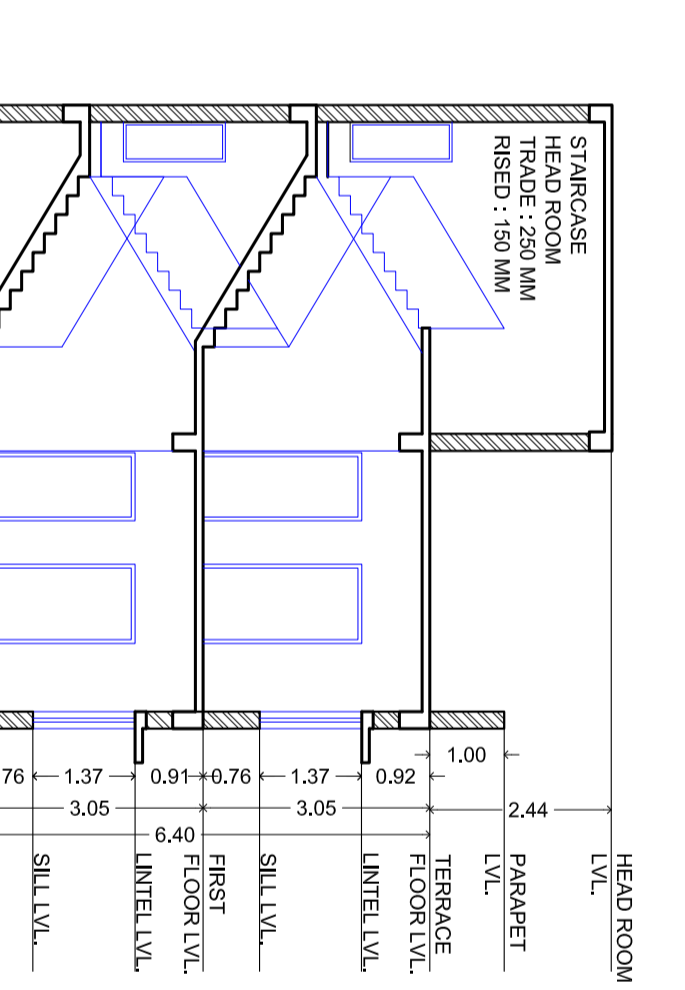
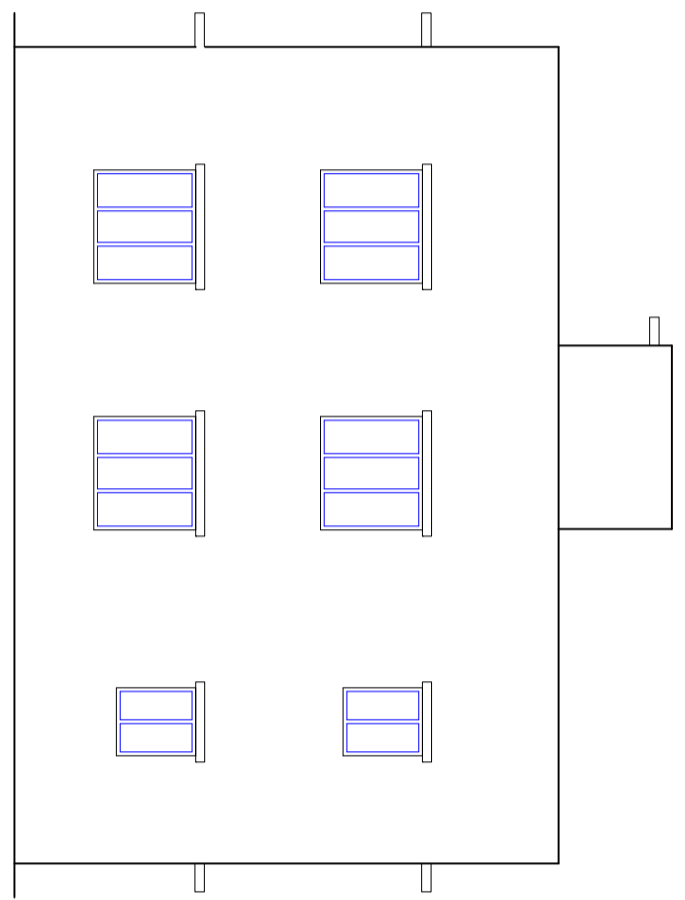
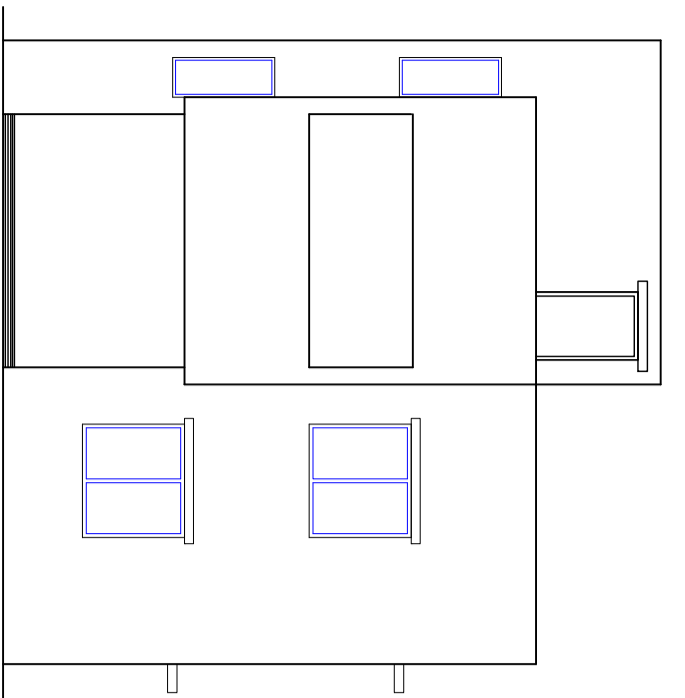

DRAWING TITLE

PROPOSED G+1 STOREIED RESIDENTIAL HOUSE

THIS IS A STANDARDIZED PRE-APPROVED PLAN PROVIDED BY

