

SANCTION TEXT

APPROVING AUTHORITY DIGITAL SIGNATURE

DOOR & WINDOW SCHEDULE		
SL. NO.	TYPE	DESCRIPTION
1	D	1.07 X 2.13 PANELLED DOOR
2	D1	0.91 X 2.13 PANELLED DOOR
3	D2	0.76 X 2.13 PANELLED DOOR
4	W	1.52 X 1.37 MS. GLAZED WINDOW
5	W1	0.91 X 1.37 MS. GLAZED WINDOW
6	W2	1.22 X 1.14 MS. GLAZED WINDOW
7	V	0.61 X 0.61 MS. GLAZED VENTILATOR

AREA AND BUILDING PARAMETERS	
PLOT DIMENSIONS (IN FEET)	30' X 50'
PLOT DIMENSIONS (IN MT)	9.14M X 15.24M
PLOT AREA	139.29 SQMT
GROUND FLOOR BUILT UP AREA	104.39 SQMT
FIRST FLOOR BUILT UP AREA	104.39 SQMT
TOTAL BUILT UP AREA	208.78 SQMT
FLOOR AREA RATIO (FAR)	1.49
BUILDING HEIGHT	6.40 MT
PLANTATION AREA	13.92 Sqm
NUMBER OF TREES PROVIDED	

APPLICANT DETAILS	
NAME OF APPLICANT	
ADDRESS	
CONTACT NUMBER	

LAND DETAILS	
REVENUE VILLAGE	
REVENUE PLOT NO	
SCHEME PLOT NO/LAYOUT	
PLOT NO./SUB PLOT NO	
KHATA NUMBER	

SITE PLAN

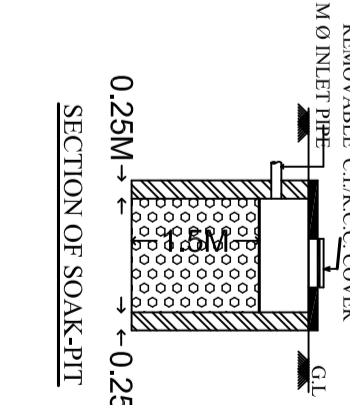
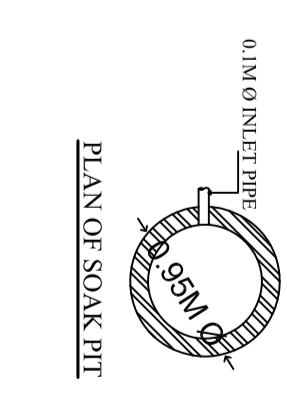
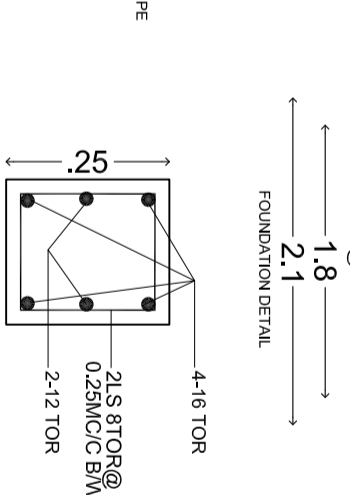
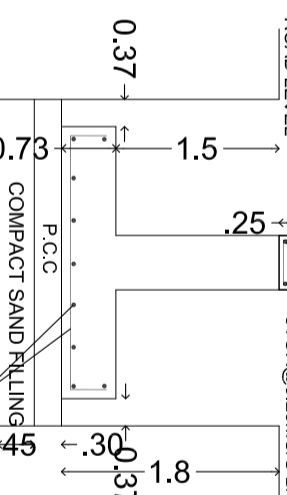
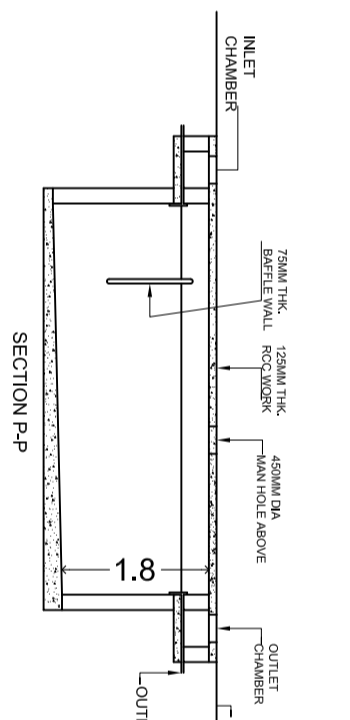
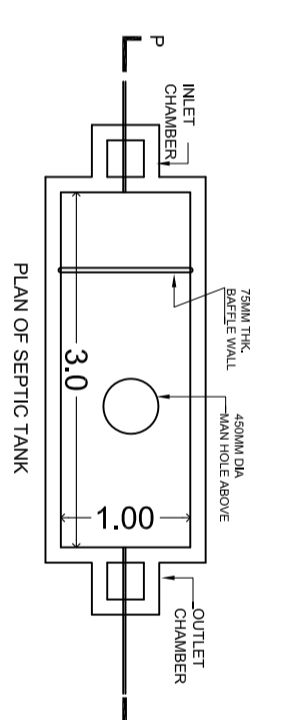
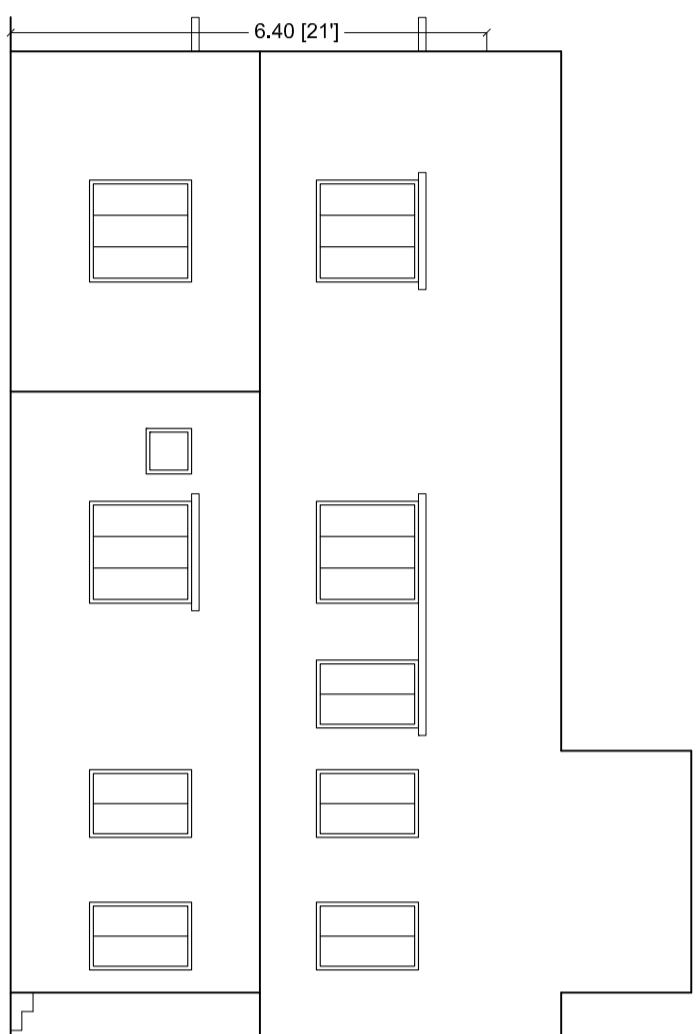
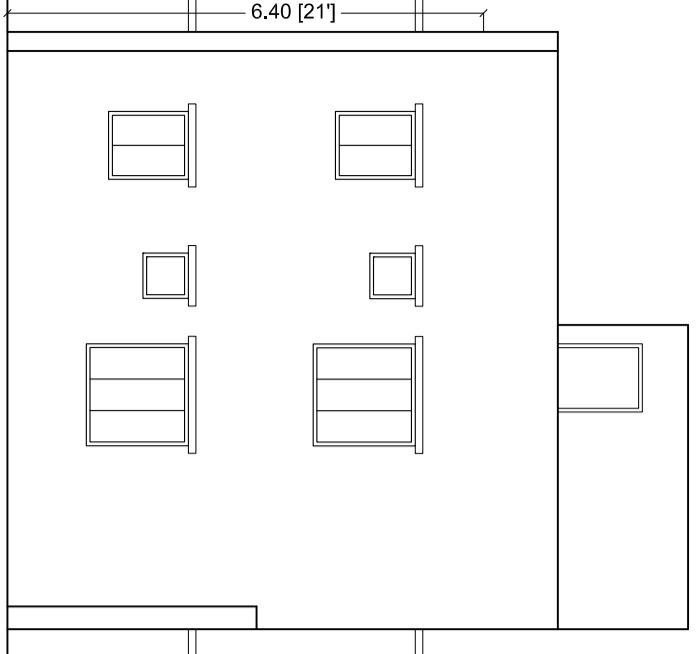
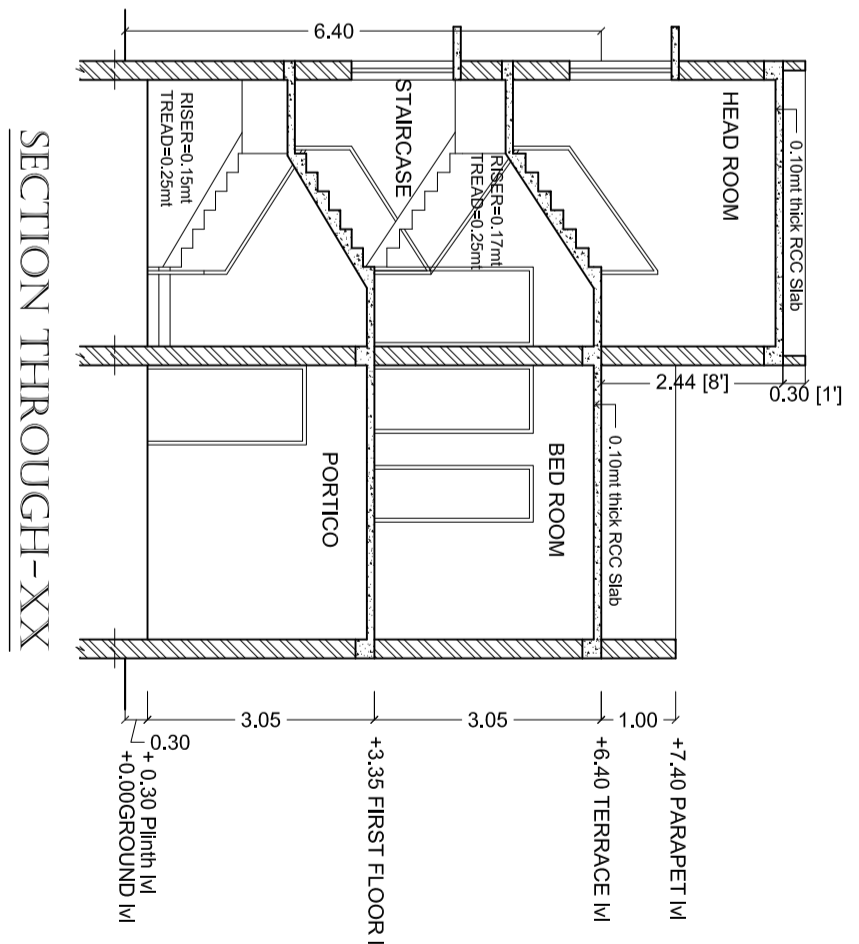
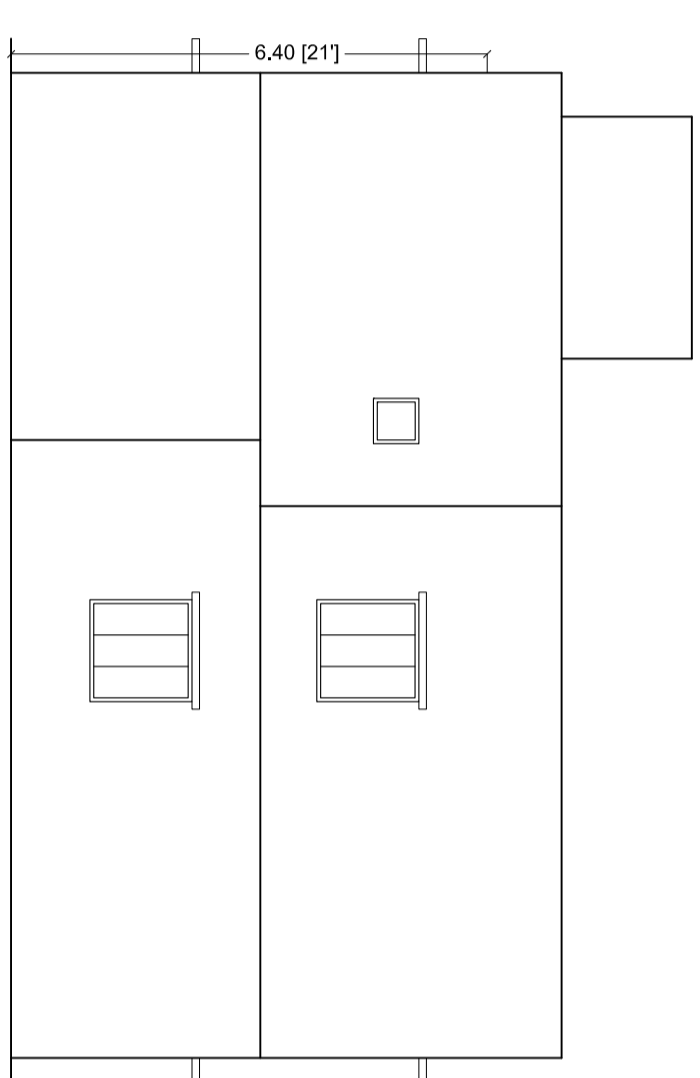
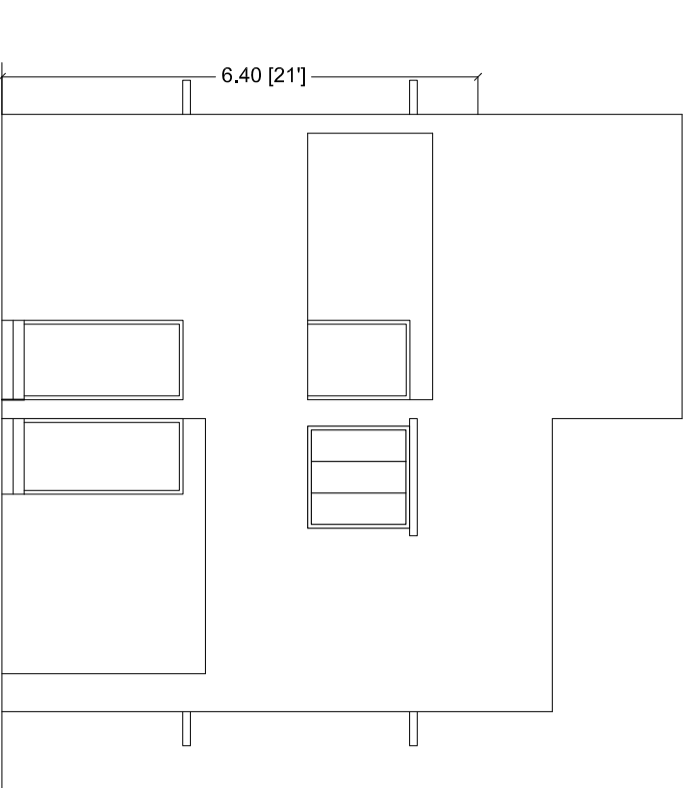
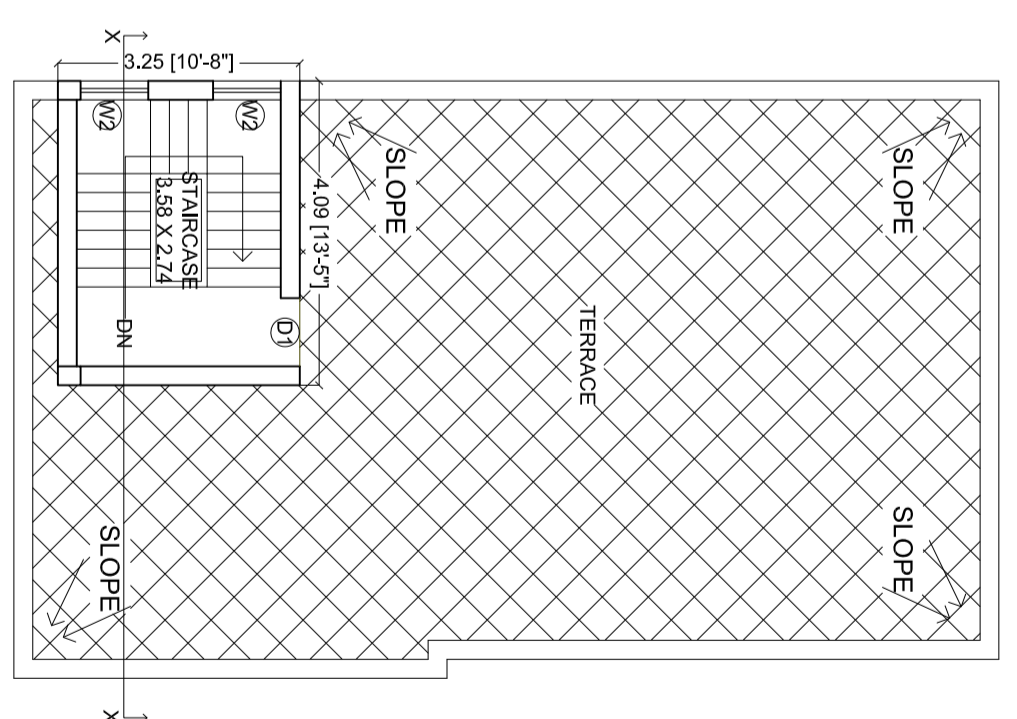
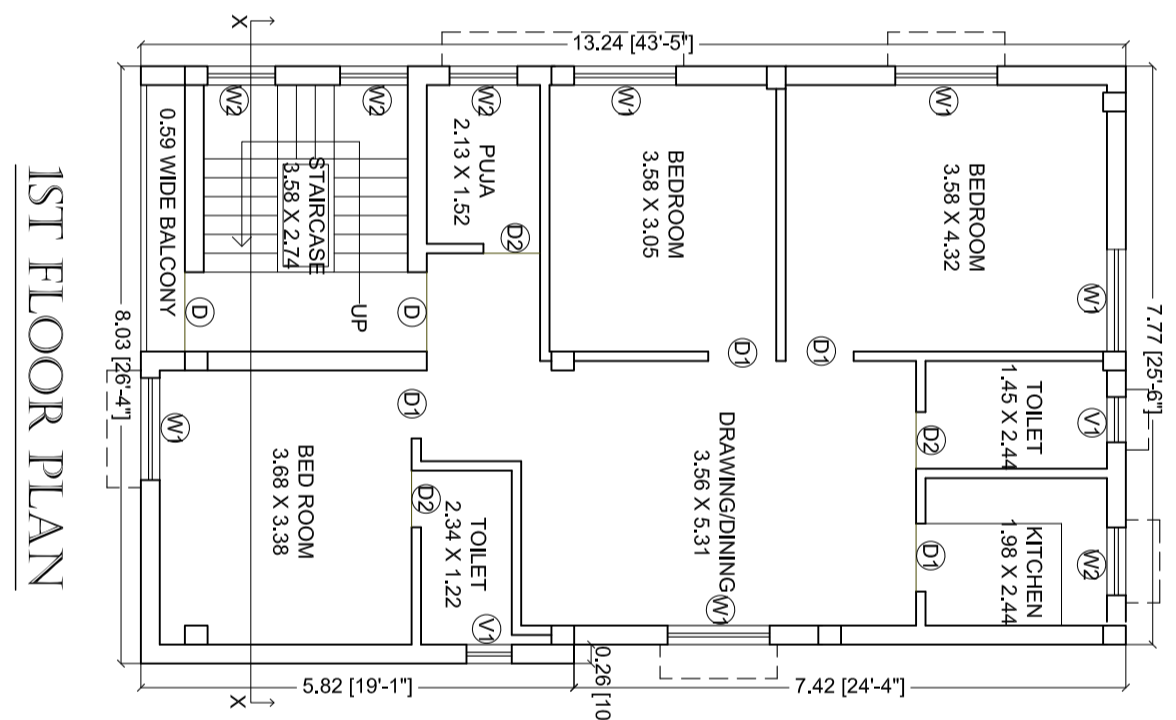
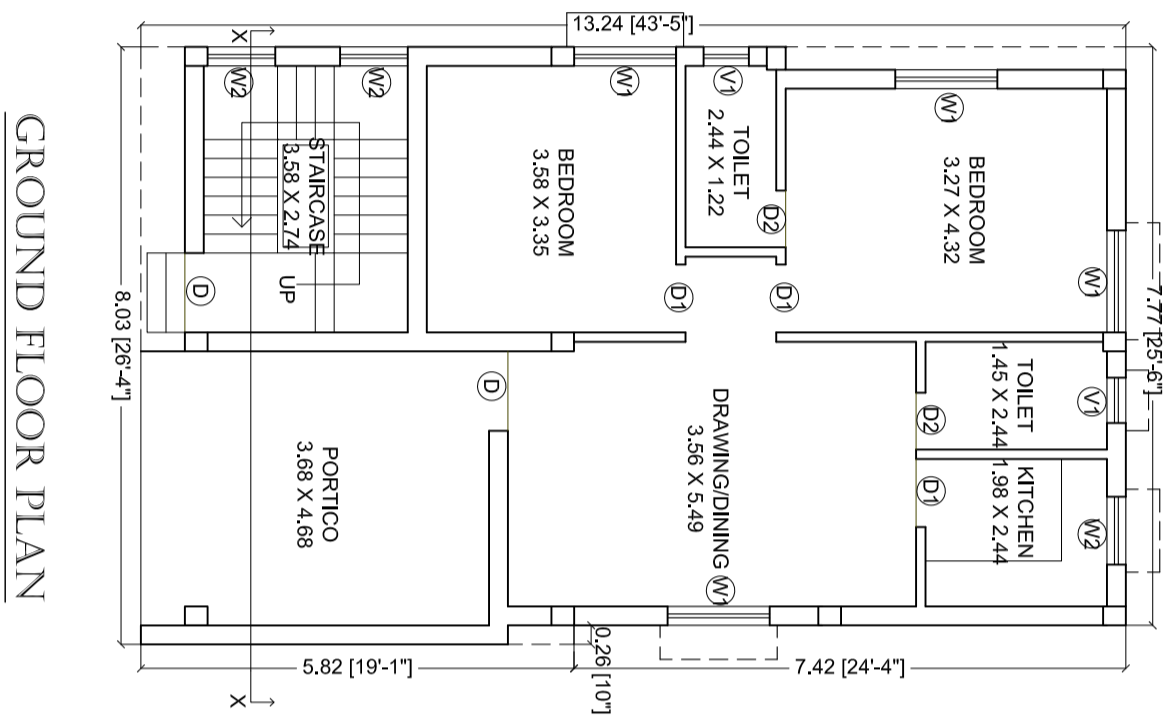
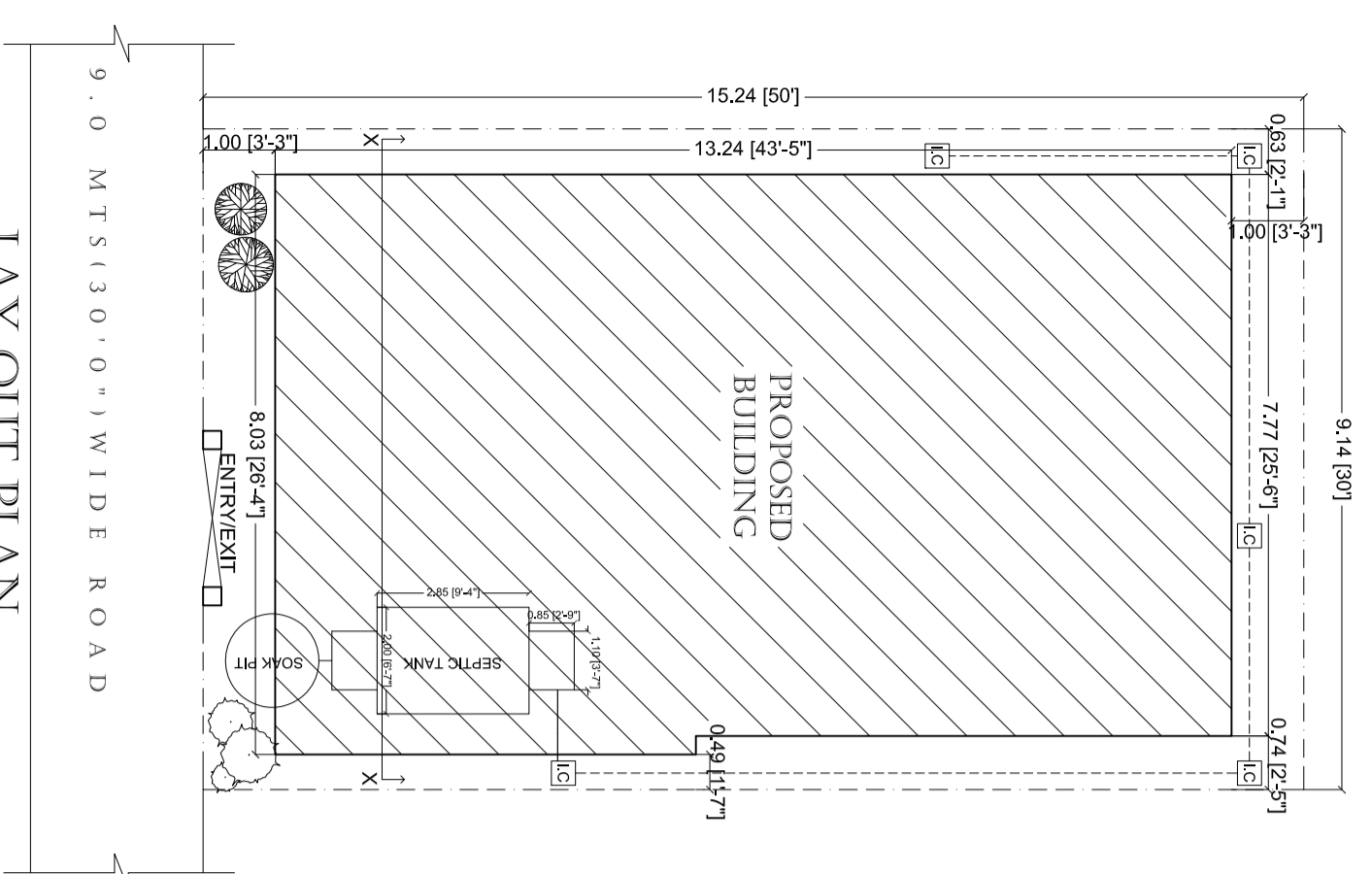

DRAWING TITLE
PROPOSED G+1 STORIED RESIDENTIAL HOUSE
THIS IS A STANDARDIZED PRE-APPROVED PLAN PROVIDED BY

