

Pre-Approved Building Plan No  
**30500904**

SANCTION TEXT

APPROVING AUTHORITY DIGITAL SIGNATURE

DOOR & WINDOW SCHEDULE		
SL. NO.	TYPE	DESCRIPTION
1	D	1.07 X 2.13 PANELLED DOOR
2	D1	0.91 X 2.13 PANELLED DOOR
3	D2	0.76 X 2.13 PANELLED DOOR
4	W	1.52 X 1.37 MS. GLAZED WINDOW
5	W1	0.91 X 1.37 MS. GLAZED WINDOW
6	W2	1.22 X 1.14 MS. GLAZED WINDOW
7	V	0.61 X 0.61 MS. GLAZED VENTILATOR

AREA AND BUILDING PARAMETERS	
PLOT DIMENSIONS (IN FEET)	30' X 50'
PLOT DIMENSIONS (IN MT)	9.14M X 15.24M
PLOT AREA	139.29 SQMT
GROUND FLOOR BUILT UP AREA	80.86 SQMT
FIRST FLOOR BUILT UP AREA	80.86 SQMT
TOTAL BUILT UP AREA	161.72 SQMT
FLOOR AREA RATIO (FAR)	1.16
BUILDING HEIGHT	6.40 MT
PLANTATION AREA	35.78 SQMT
NUMBER OF TREES PROVIDED	02 NOS

APPLICANT DETAILS	
NAME OF APPLICANT	
ADDRESS	
CONTACT NUMBER	

LAND DETAILS	
REVENUE VILLAGE	
REVENUE PLOT NO	
SCHEME PLOT NO/LAYOUT PLOT NO/ SUB PLOT NO	
KHATA NUMBER	

SITE PLAN

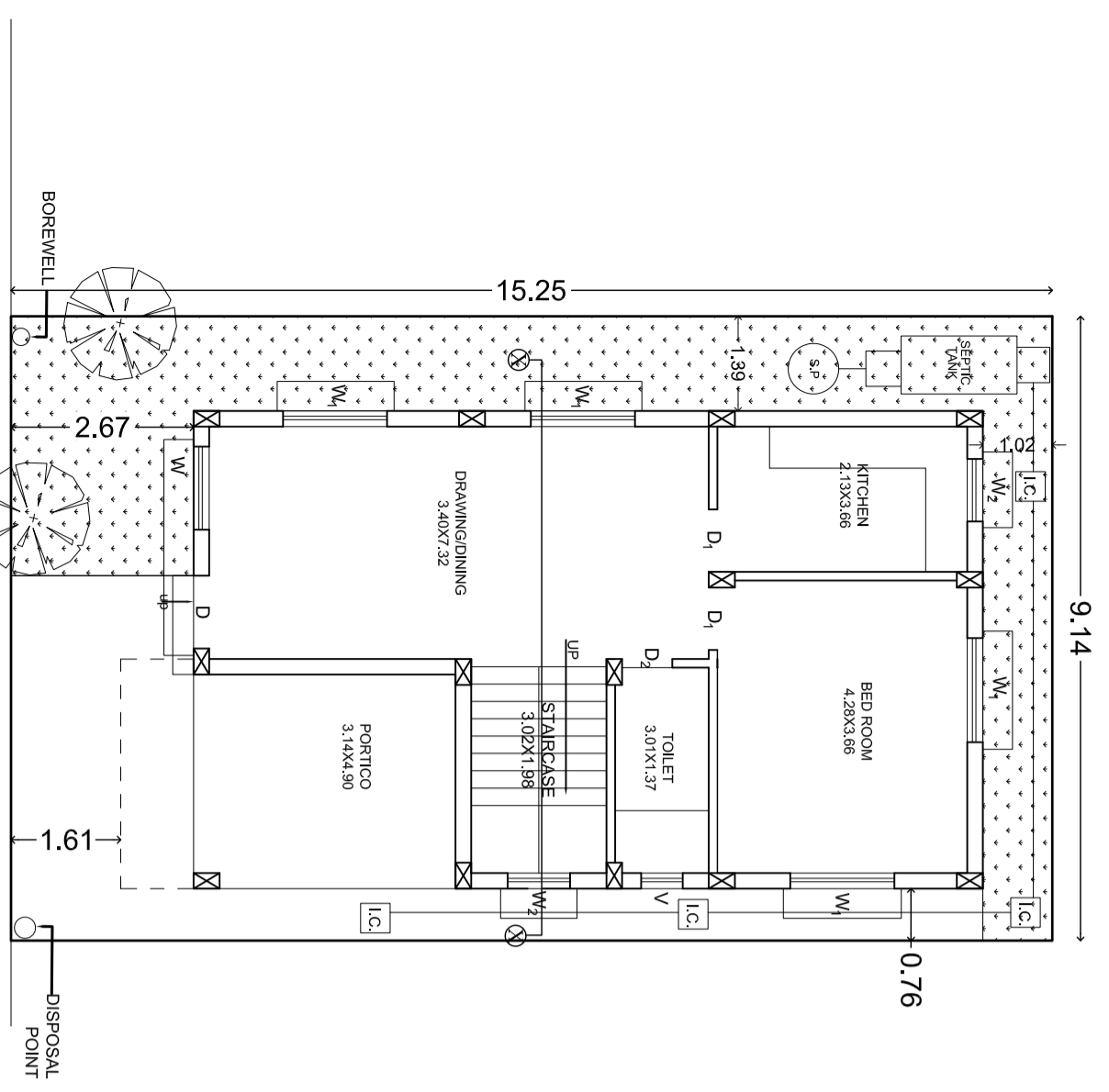

SITE LAYOUT CUM GROUND FLOOR PLAN

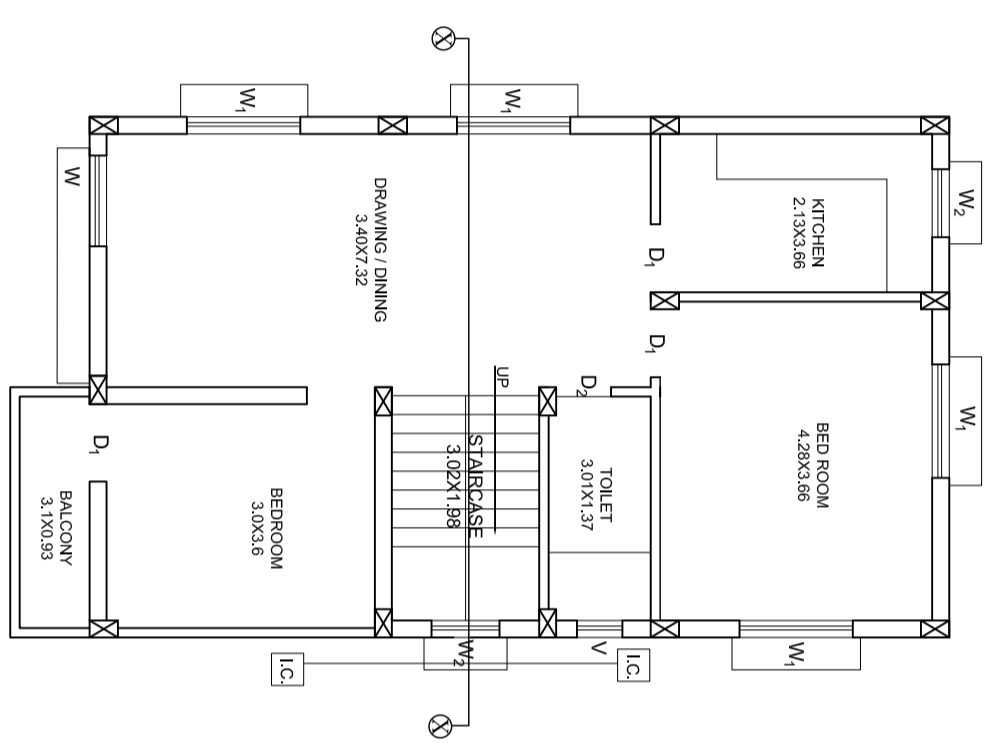

FIRST FLOOR PLAN

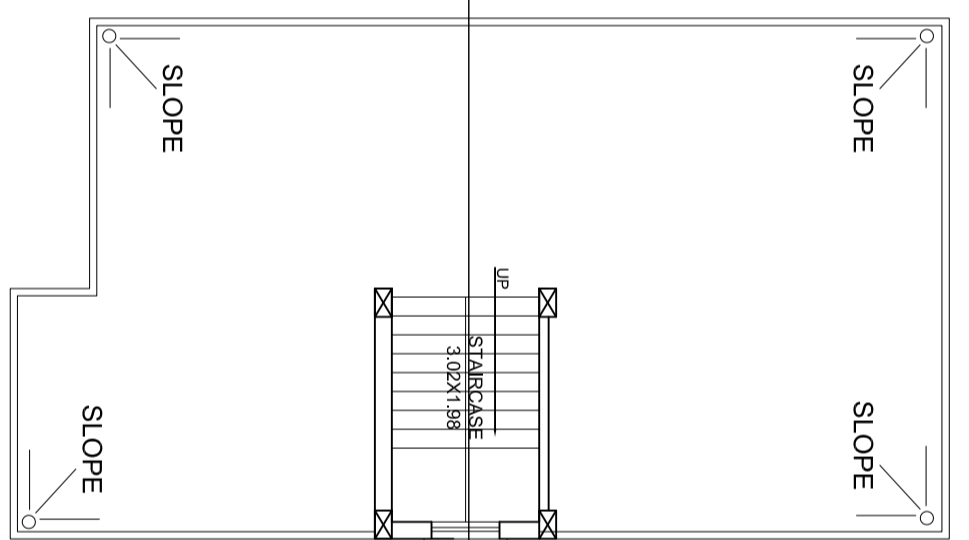

TERRACE FLOOR PLAN

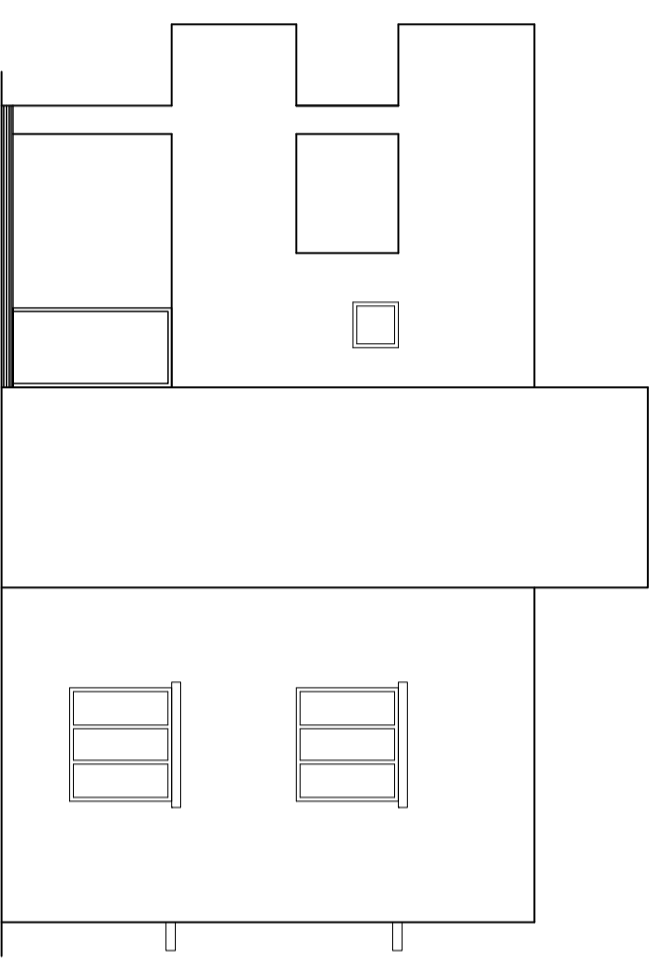

FRONT ELEVATION

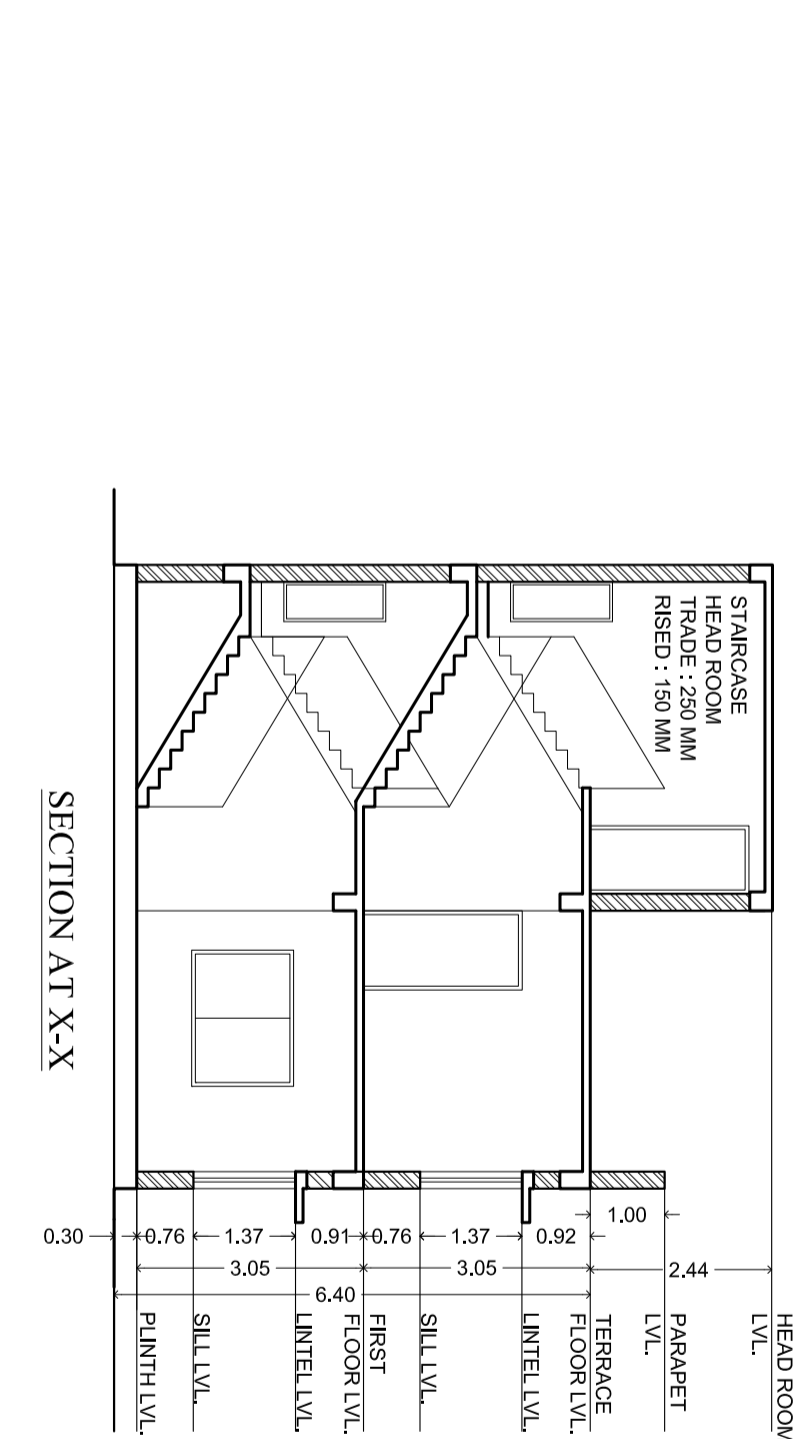

SECTION AT X-X

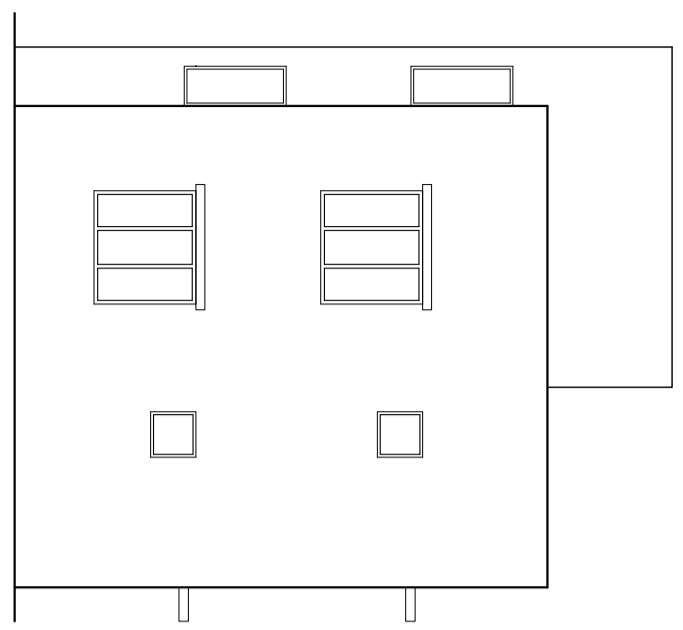

REAR ELEVATION

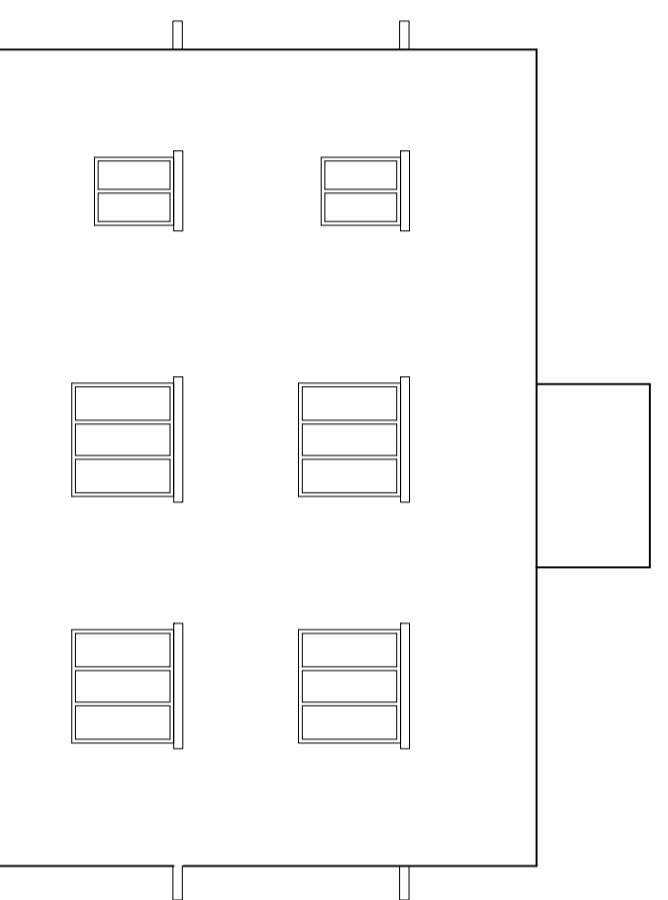

LEFT SIDE ELEVATION

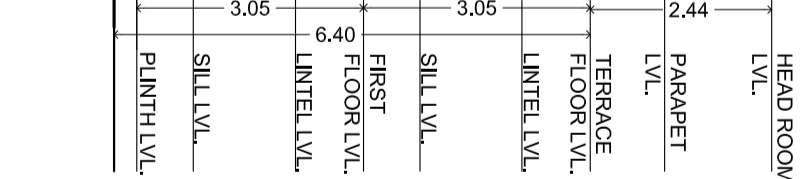

RIGHT SIDE ELEVATION

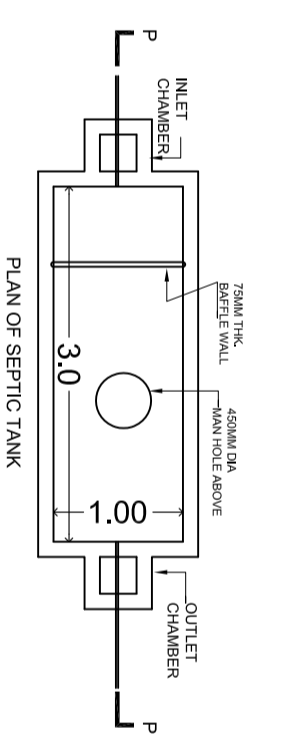

PLAN OF SEPTIC TANK

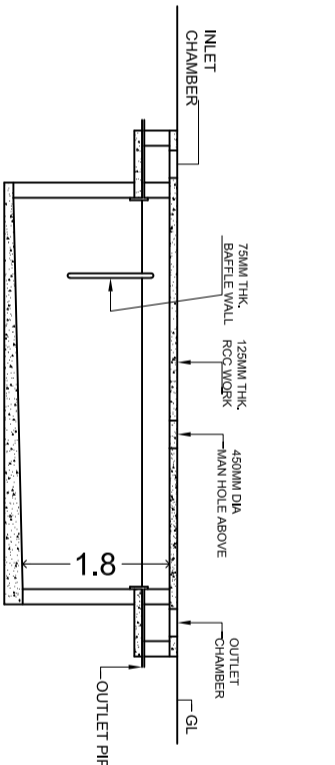

SECTION P-P

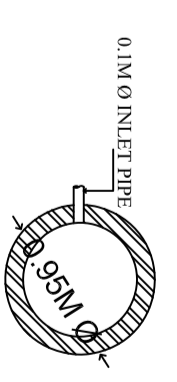

PLAN OF SOAK PIT

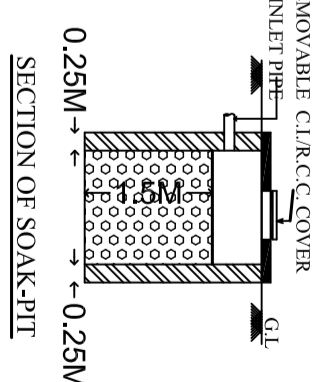

SECTION OF SOAK-PIT

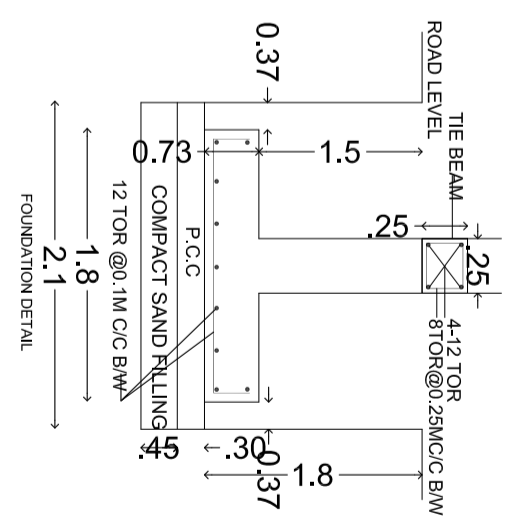

FOUNDATION DETAIL

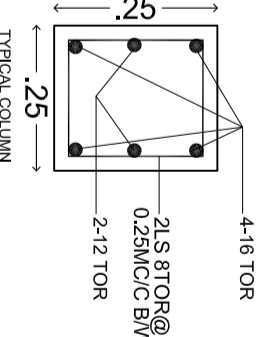

TYPICAL COLUMN

DETAILINGS

DRAWING-TITLE  
**PROPOSED G+1 STORIED RESIDENTIAL HOUSE**  
THIS IS A STANDARDIZED PRE-APPROVED PLAN PROVIDED BY

