

Pre-Approved Building Plan No
30500903

SANCTION TEXT

APPROVING AUTHORITY DIGITAL SIGNATURE

DOOR & WINDOW SCHEDULE			
SL. NO.	TYPE	SIZE	DESCRIPTION
1	D	1.07 X 2.13	PANELLED DOOR
2	D1	0.91 X 2.13	PANELLED DOOR
3	D2	0.76 X 2.13	PANELLED DOOR
4	W	1.52 X 1.37	MS. GLAZED WINDOW
5	W1	0.91 X 1.37	MS. GLAZED WINDOW
6	W2	1.22 X 1.14	MS. GLAZED WINDOW
7	V	0.61 X 0.61	MS. GLAZED VENTILATOR

AREA AND BUILDING PARAMETERS			
PLOT DIMENSIONS (IN FEET)	30' X 50'	PLOT DIMENSIONS (IN MT)	9.14M X 15.24M
PLOT AREA	139.38 SQMT	GROUND FLOOR BUILT UP AREA	89.88 SQMT
FIRST FLOOR BUILT UP AREA	89.88 SQMT	TOTAL BUILT UP AREA	179.76 SQMT
FLOOR AREA RATIO (FAR)	1.28	BUILDING HEIGHT	6.40 MT
PLANTATION AREA	35.78 SQMT	NUMBER OF TREES PROVIDED	02 NOS

APPLICANT DETAILS	
NAME OF APPLICANT	
ADDRESS	
CONTACT NUMBER	

LAND DETAILS	
REVENUE VILLAGE	
REVENUE PLOT NO	
SCHEME PLOT NO/LAYOUT	
PLOT NO./SUB PLOT NO	
KHATA NUMBER	

SITE PLAN

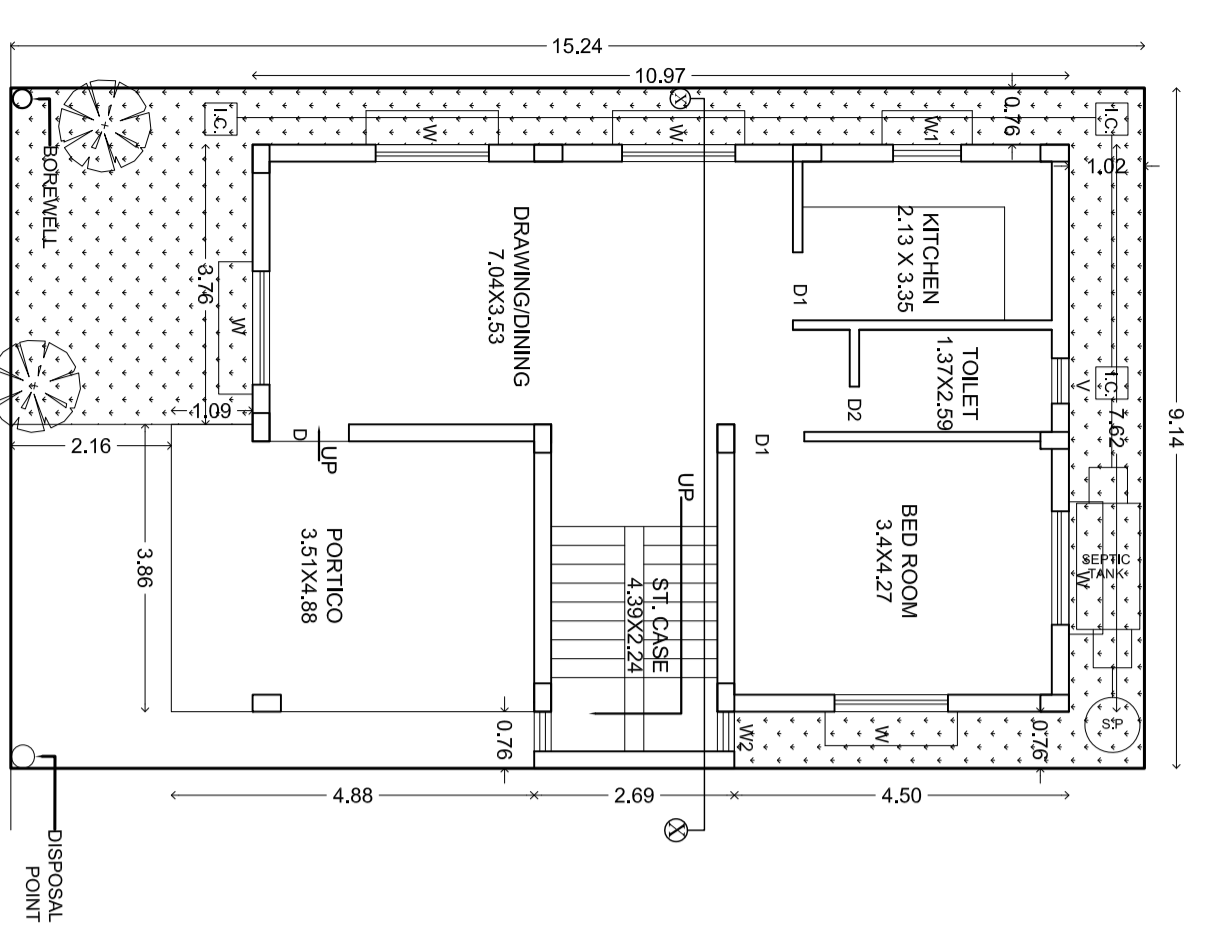

SITE LAYOUT cum GROUND FLOOR PLAN

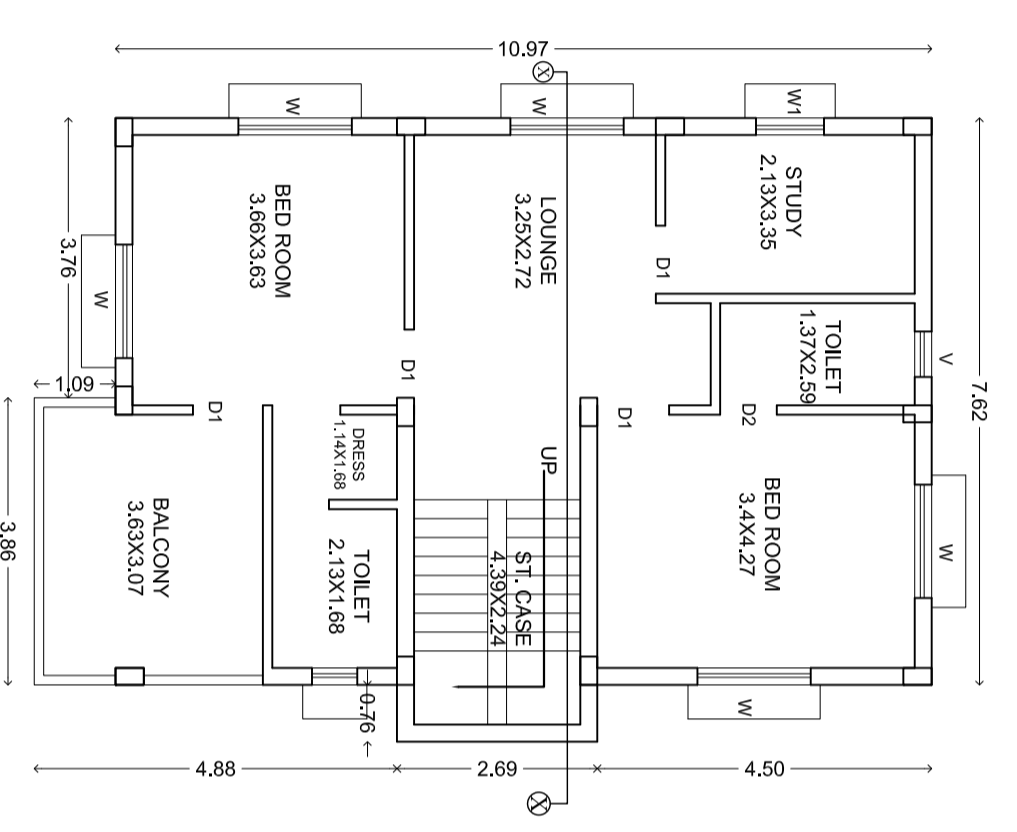

FIRST FLOOR PLAN

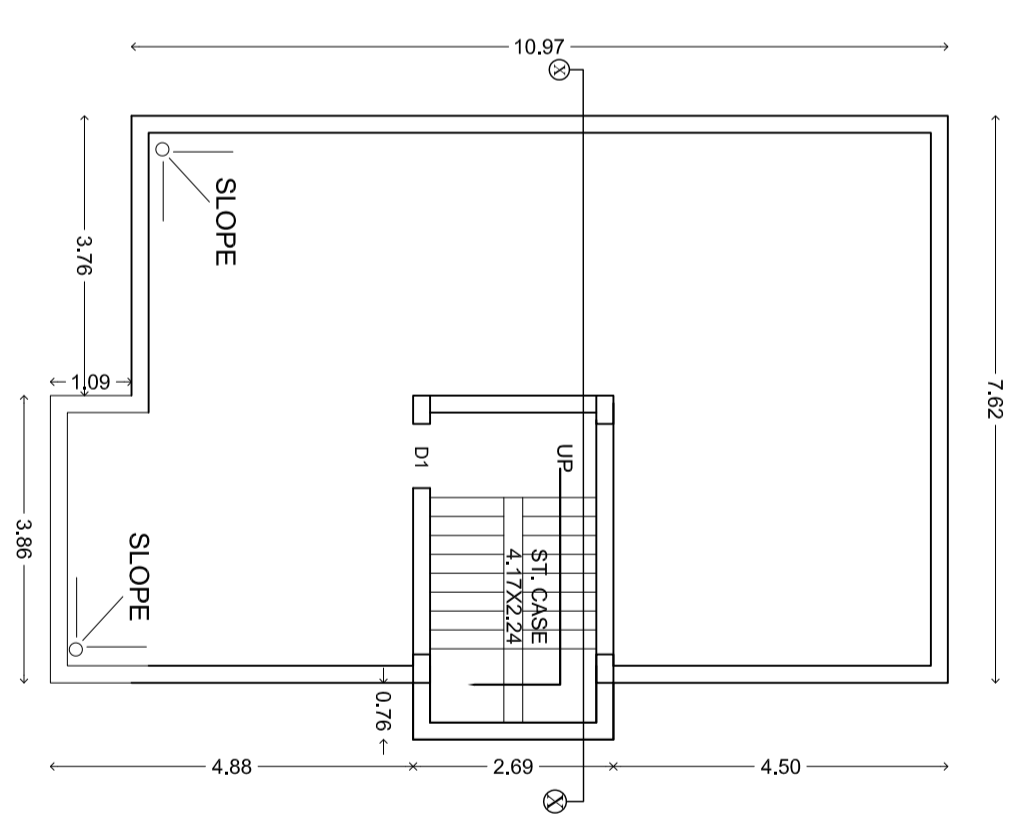

TERRACE FLOOR PLAN

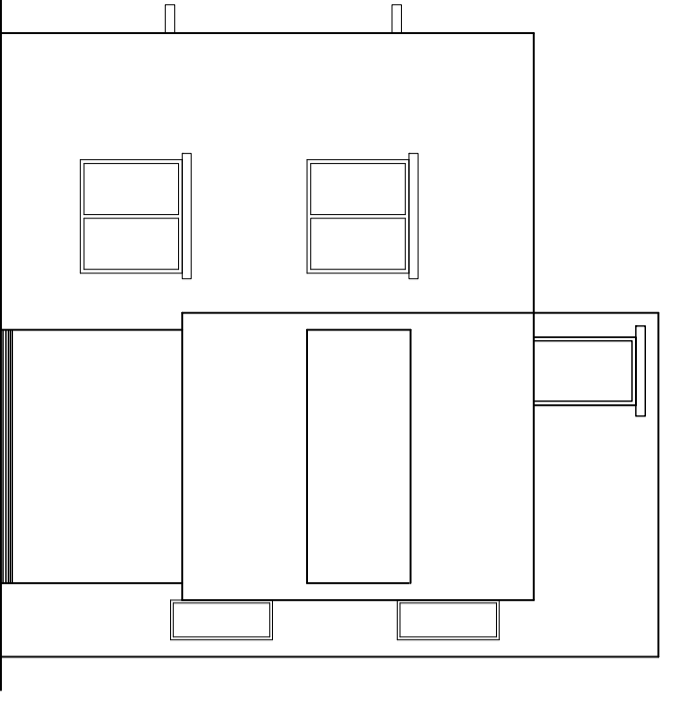

FRONT ELEVATION

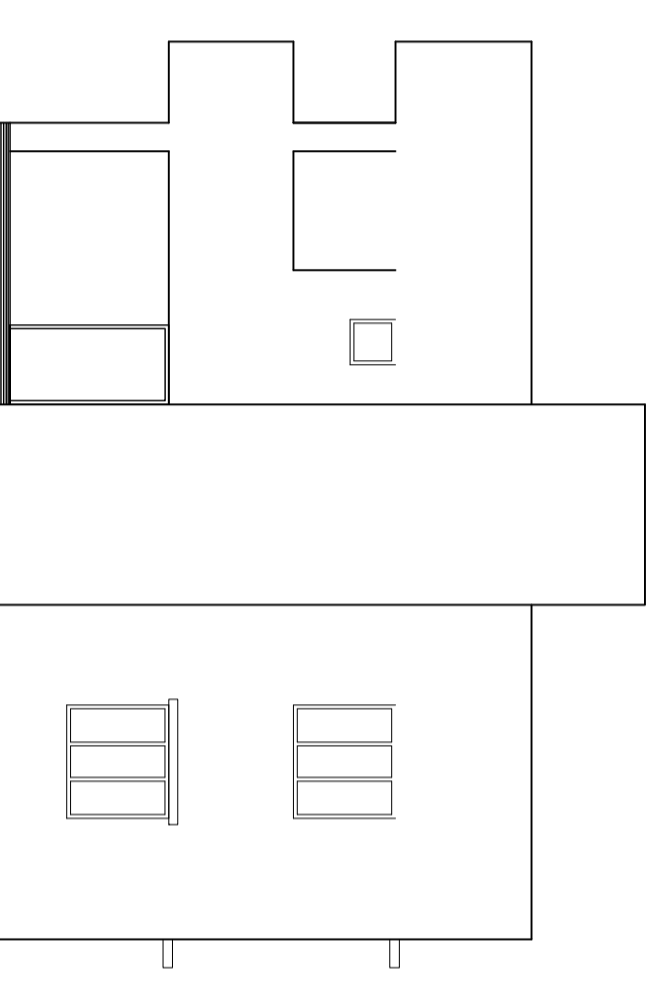

RIGHT SIDE ELEVATION

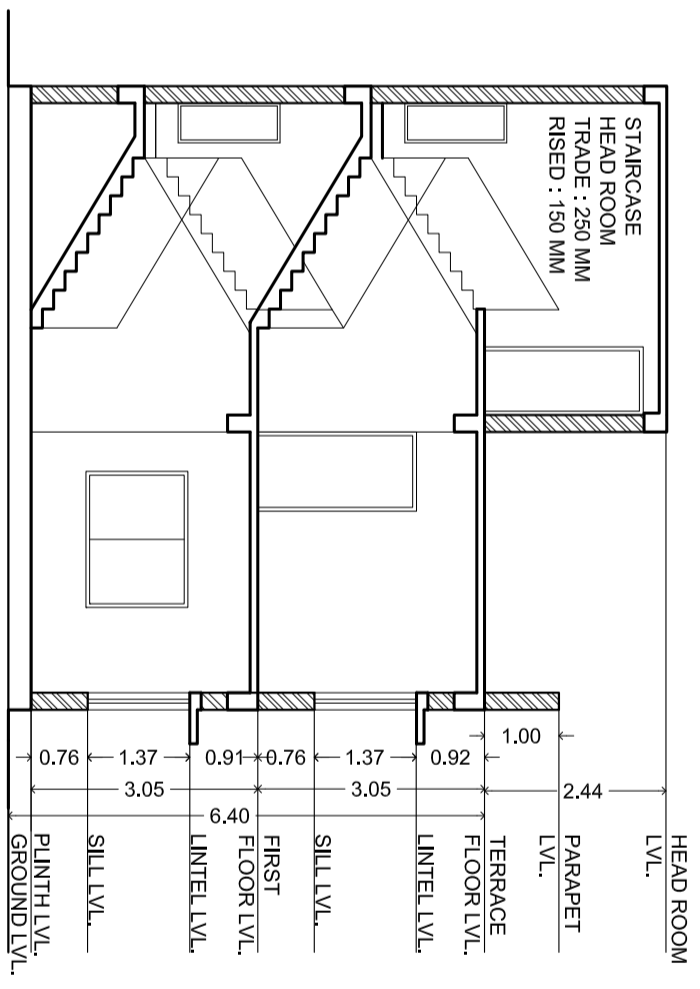

SECTION AT X-X

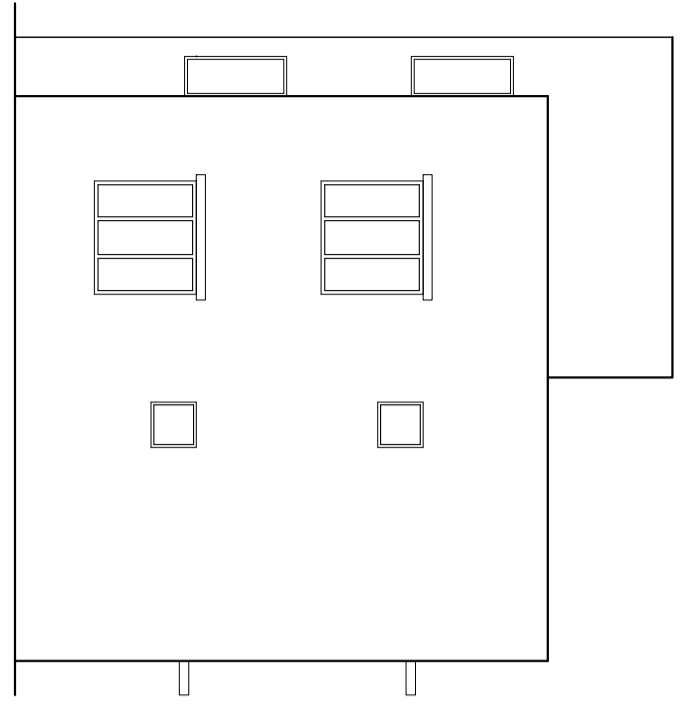

REAR ELEVATION

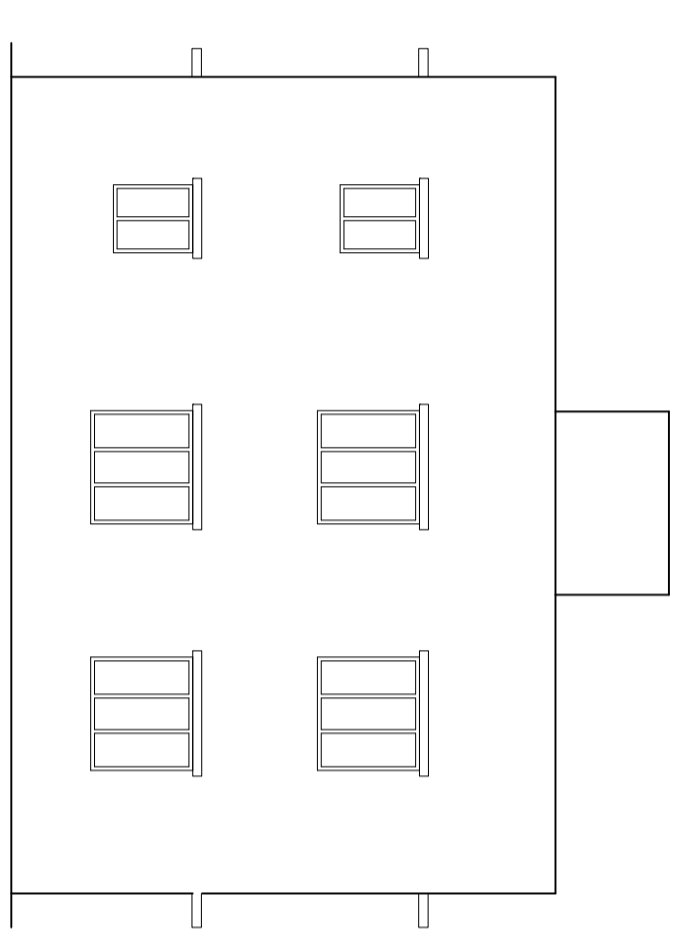

LEFT SIDE ELEVATION

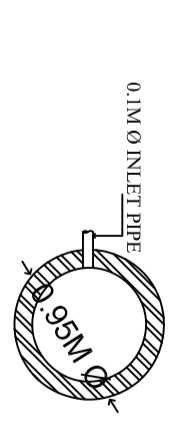

PLAN OF SOAK PIT

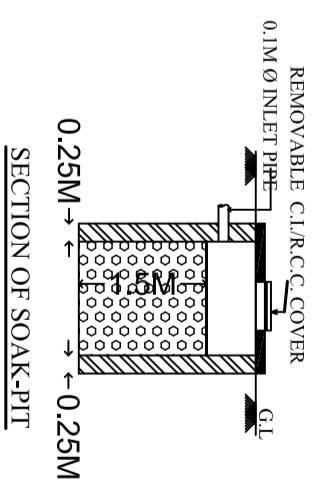

SECTION OF SOAK-PIT

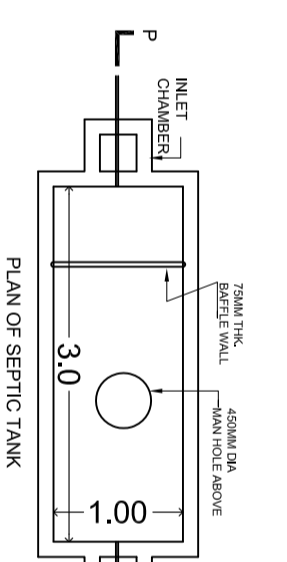

PLAN OF SEPTIC TANK

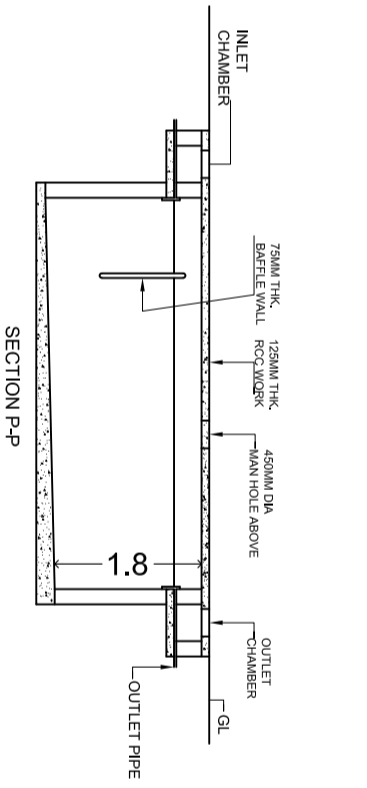

SECTION P-P

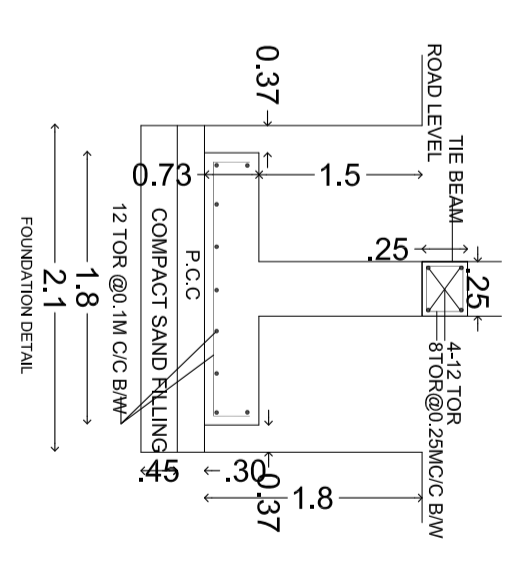

FOUNDATION DETAIL

DETAILINGS

DRAWING-TITLE
**PROPOSED G+1 STORIED
RESIDENTIAL HOUSE**

THIS IS A STANDARDIZED PRE-APPROVED
PLAN PROVIDED BY

