

SANCTION TEXT

APPROVING AUTHORITY DIGITAL SIGNATURE

DOOR & WINDOW SCHEDULE

SL. NO.	TYPE	SIZE	DESCRIPTION
1	D	1.07 X 2.13	PANELLED DOOR
2	D1	0.91 X 2.13	PANELLED DOOR
3	W	1.52 X 1.37	MS. GLAZED WINDOW
4	V	0.61 X 0.61	MS. GLAZED VENTILATOR

AREA AND BUILDING PARAMETERS

PLOT DIMENSIONS (IN FEET)	25' X 50'
PLOT DIMENSIONS (IN MT)	7.62M X 15.24M
PLOT AREA	116.12 SQMT
GROUND FLOOR BUILT UP AREA	93.78 SQMT
FIRST FLOOR BUILT UP AREA	0 SQMT
TOTAL BUILT UP AREA	77.66 SQMT
FLOOR AREA RATIO (FAR)	0.80
BUILDING HEIGHT	3.45 MT
PLANTATION AREA	
NUMBER OF TREES PROVIDED	2 NO.

APPLICANT DETAILS

NAME OF APPLICANT	
ADDRESS	
CONTACT NUMBER	

LAND DETAILS

REVENUE VILLAGE	
REVENUE PLOT NO	
SCHEME PLOT NO/LAYOUT	
PLOT NO/SUB PLOT NO	
KHATA NUMBER	

SITE PLAN

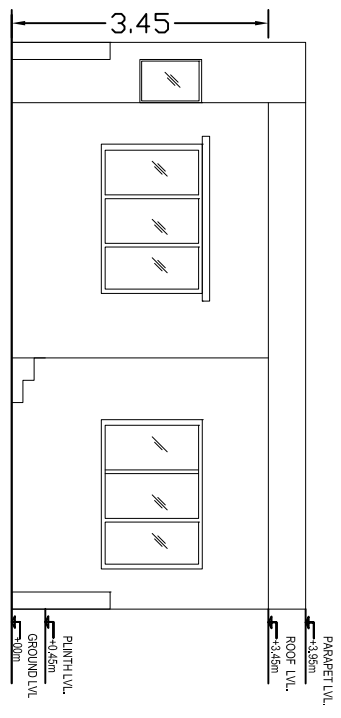

FRONT ELEVATION

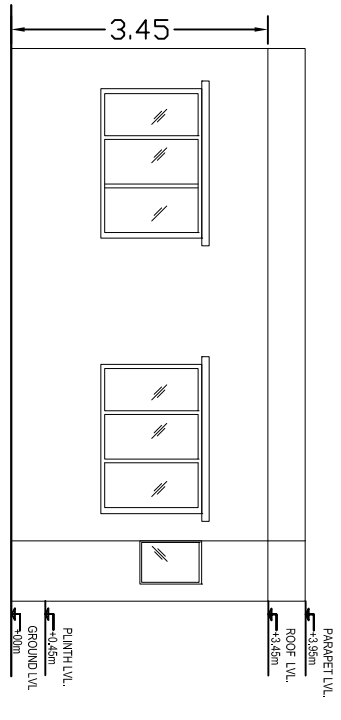

REAR ELEVATION

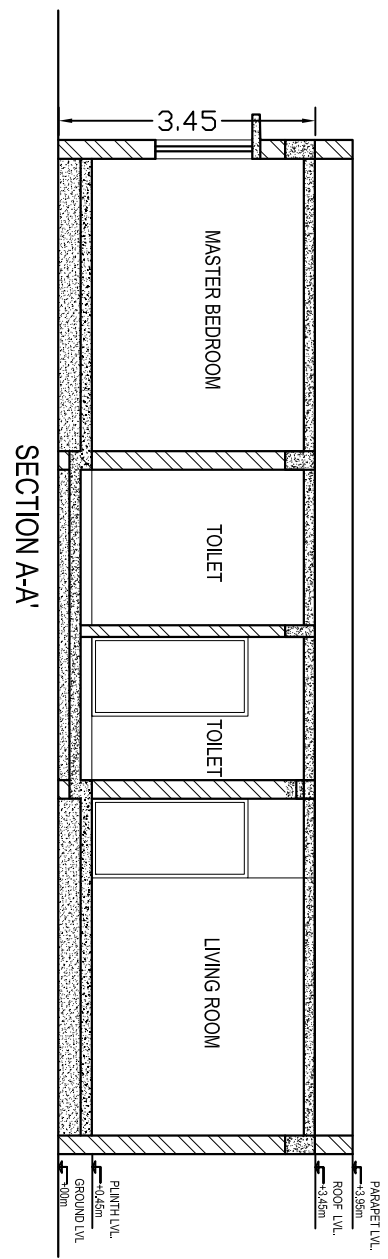

SECTION A-A

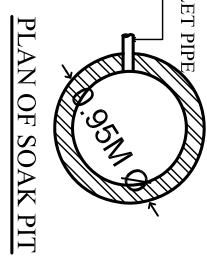

PLAN OF SOAK PIT

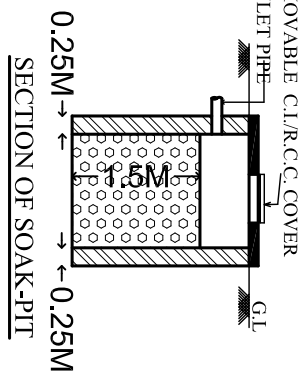

SECTION OF SOAK-PIT

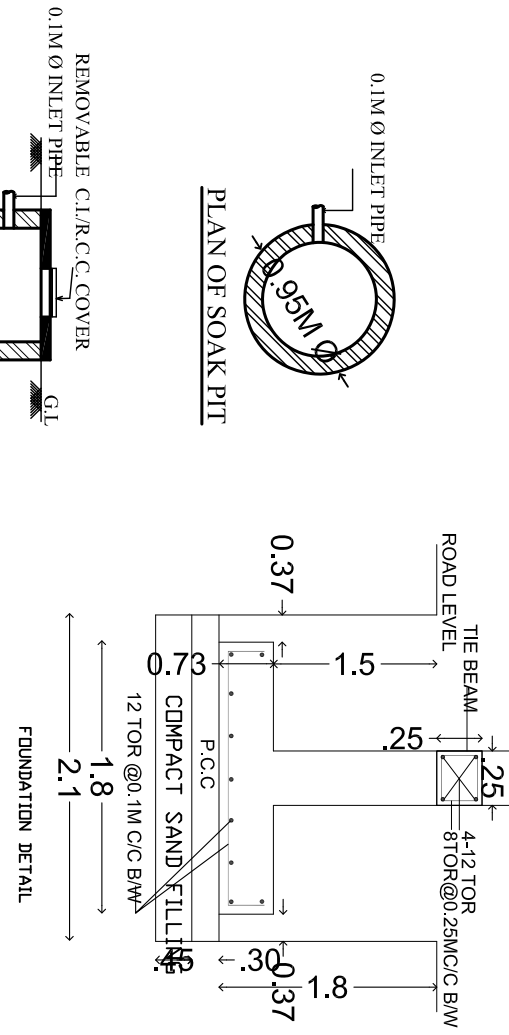

FOUNDATION DETAIL

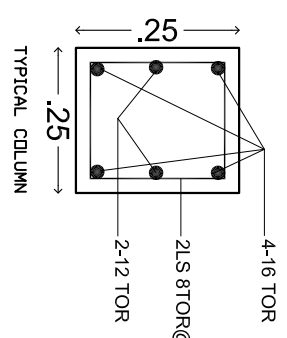

TYPICAL COLUMN

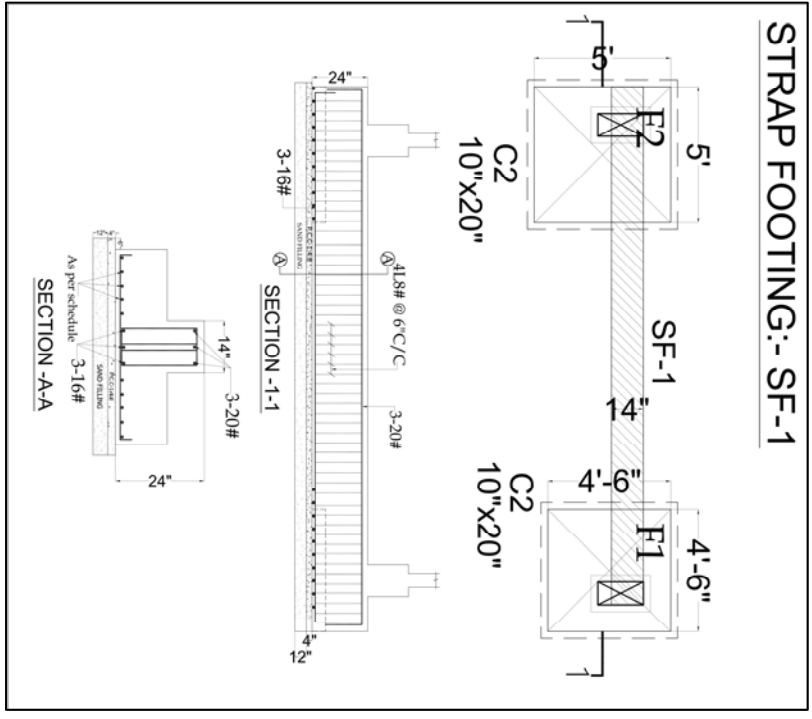

STRAP FOOTING:- SF-1

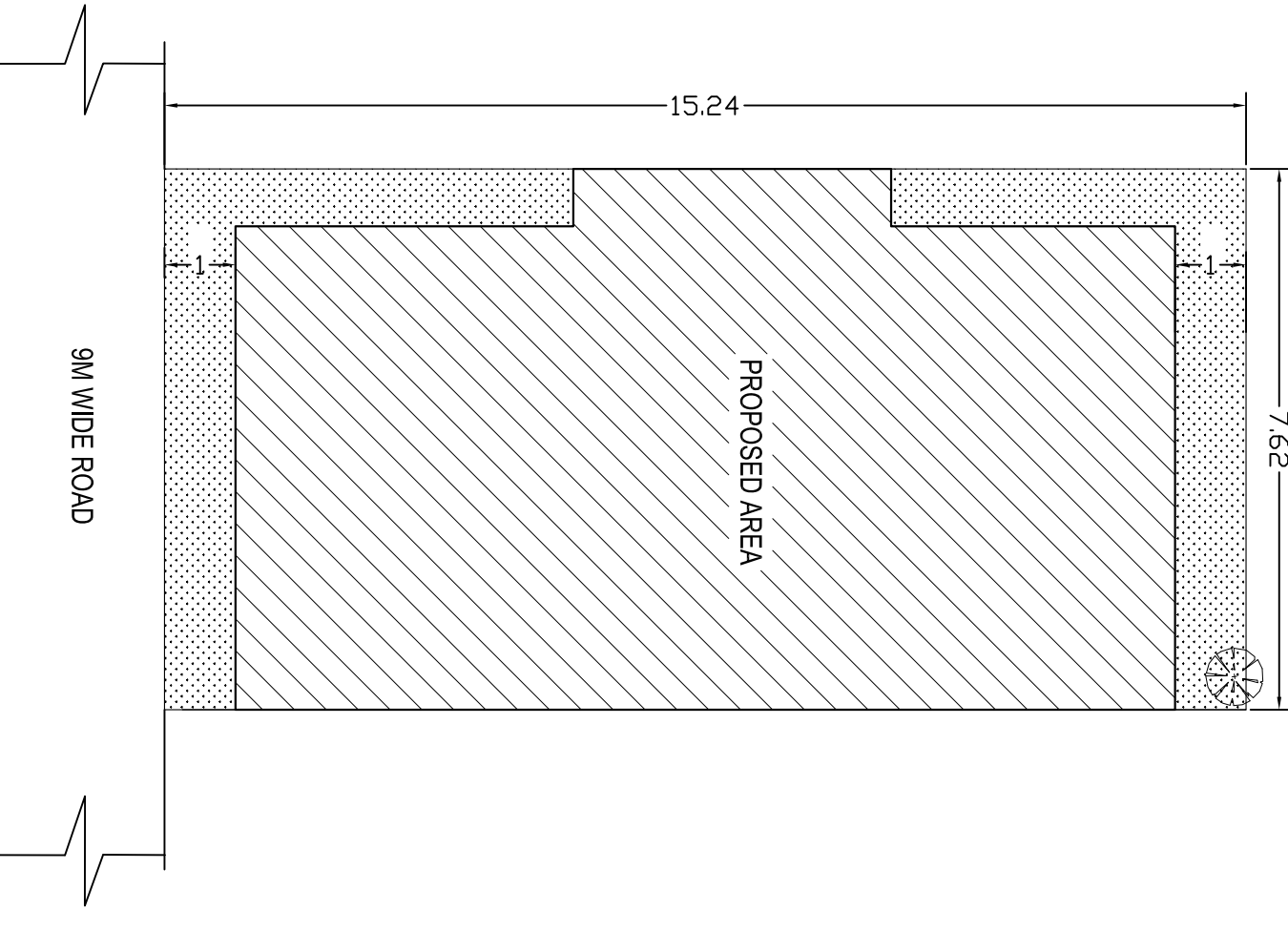

SITE PLAN

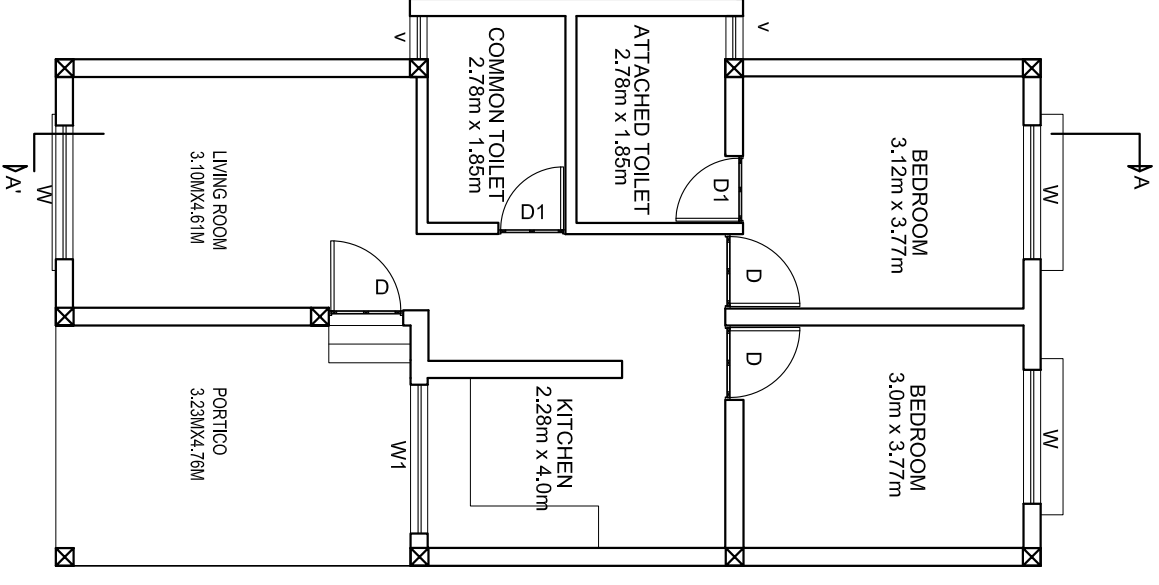

GROUND FLOOR PLAN

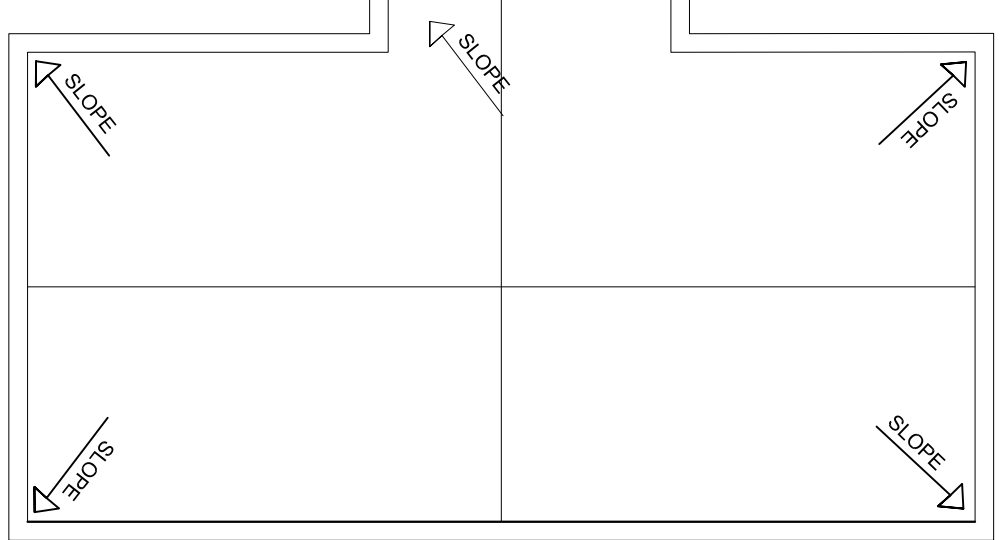

TERRACE PLAN

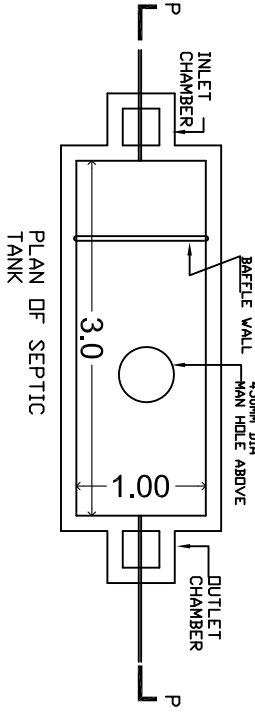

PLAN OF SEPTIC TANK

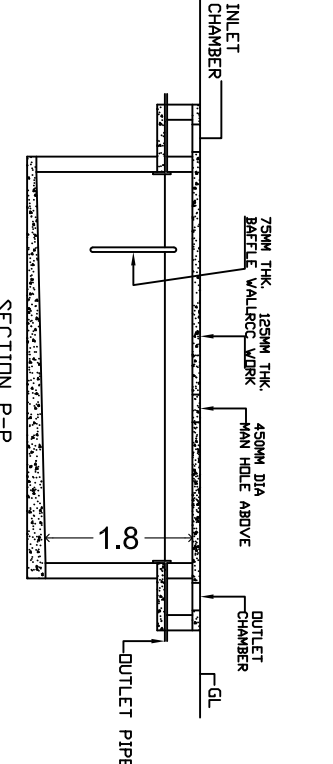

SECTION P-P

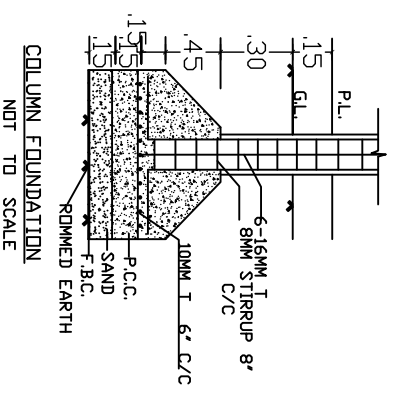

COLUMN FOUNDATION

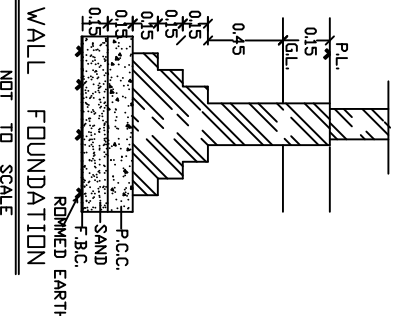

WALL FOUNDATION

PROPOSED SINGLE STORED RESIDENTIAL HOUSE

THIS IS A STANDARDIZED PRE-APPROVED PLAN PROVIDED BY

