

Pre-Approved Building Plan No  
**25500903**

SANCTION TEXT

APPROVING AUTHORITY DIGITAL SIGNATURE

DOOR & WINDOW SCHEDULE			
SL. NO.	TYPE	SIZE	DESCRIPTION
1	D	1.07 X 2.13	PANELLED DOOR
2	D1	0.91 X 2.13	PANELLED DOOR
3	D2	0.76 X 2.13	PANELLED DOOR
4	W	1.52 X 1.37	MS. GLAZED WINDOW
5	W1	0.91 X 1.37	MS. GLAZED WINDOW
6	W2	1.22 X 1.14	MS. GLAZED WINDOW
7	V	0.61 X 0.61	MS. GLAZED VENTILATOR

AREA AND BUILDING PARAMETERS			
PLOT DIMENSIONS (IN FEET)	25' X 50'	PLOT DIMENSIONS (IN MT)	7.62 M X 15.24M
PLOT AREA	116.13 SQMT	GROUND FLOOR BUILT UP AREA	82.48 SQMT
FIRST FLOOR BUILT UP AREA	82.48 SQMT	TOTAL BUILT UP AREA	164.96 SQMT
FLOOR AREA RATIO (FAR)	1.42	BUILDING HEIGHT	6.40 MT
PLANTATION AREA	11.67 SQMT	NUMBER OF TREES PROVIDED	02 NOS

APPLICANT DETAILS	
NAME OF APPLICANT	
ADDRESS	
CONTACT NUMBER	
LAND DETAILS	
REVENUE VILLAGE	
REVENUE PLOT NO	
SCHEME PLOT NO./LAYOUT	
PLOT NO./SUB PLOT NO	
KHATA NUMBER	

SITE PLAN

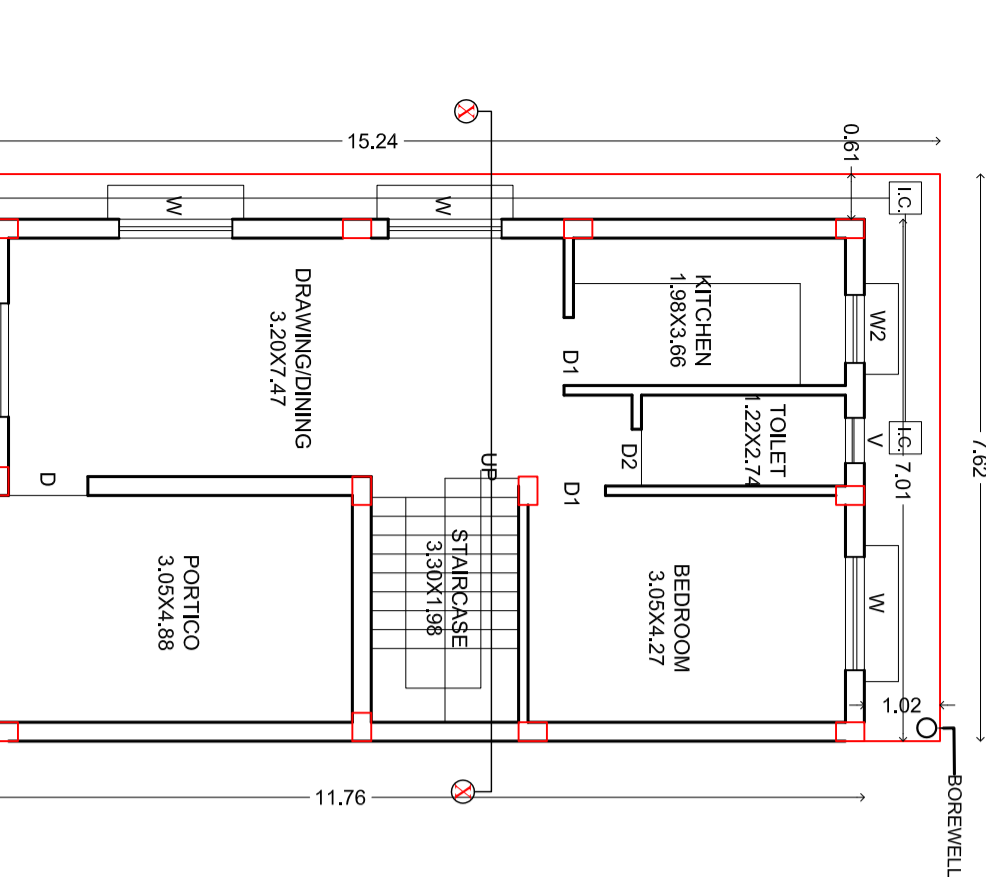

SITE LAYOUT CUM GROUND FLOOR PLAN

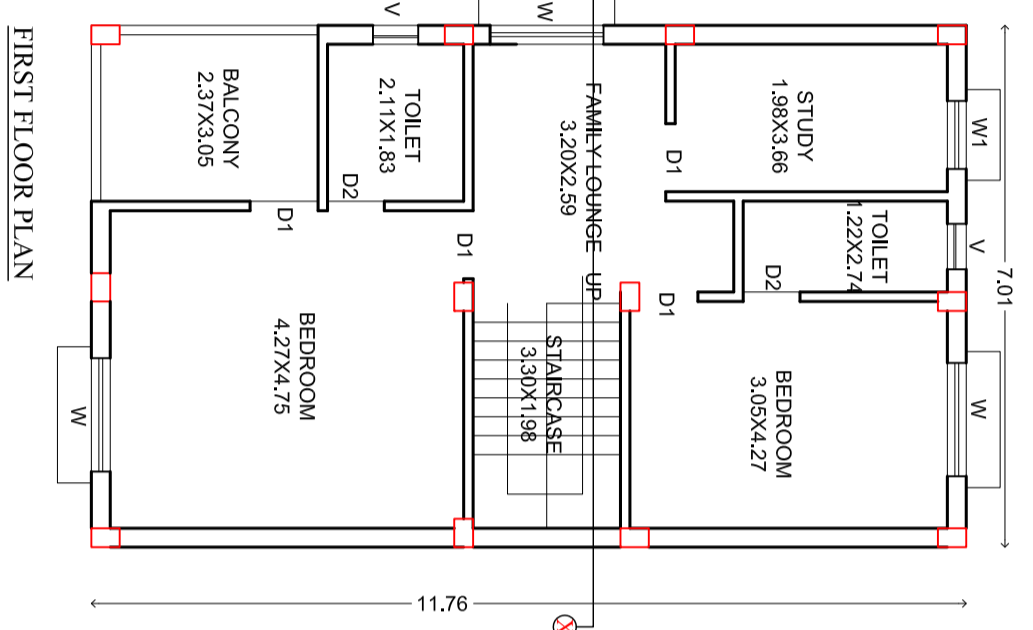

FIRST FLOOR PLAN

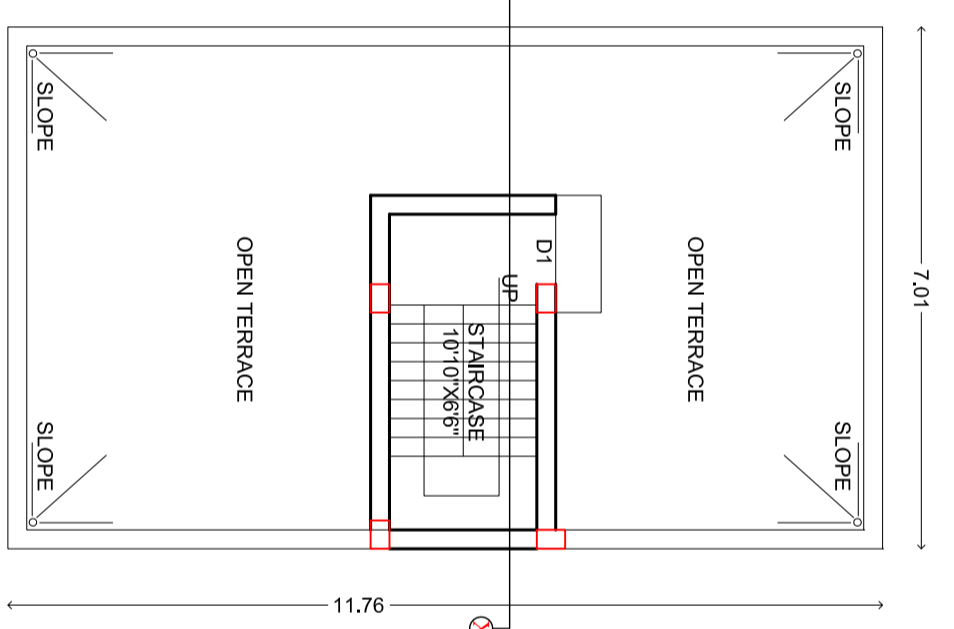

TERRACE PLAN

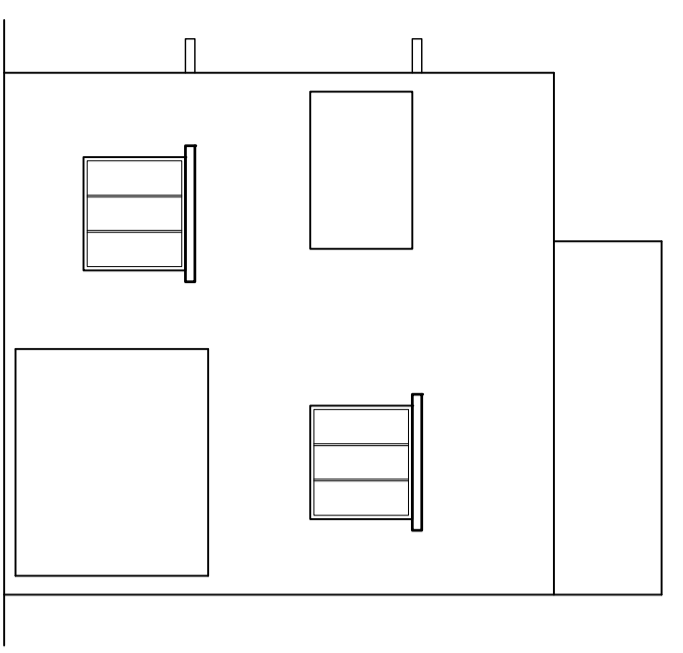

FRONT ELEVATION

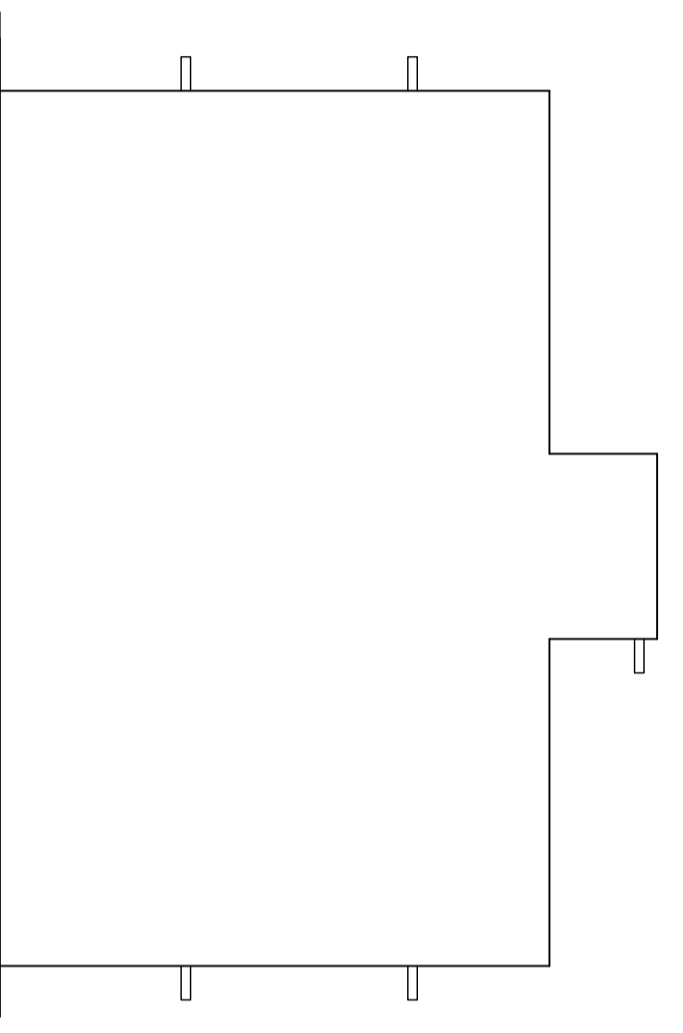

RIGHT SIDE ELEVATION

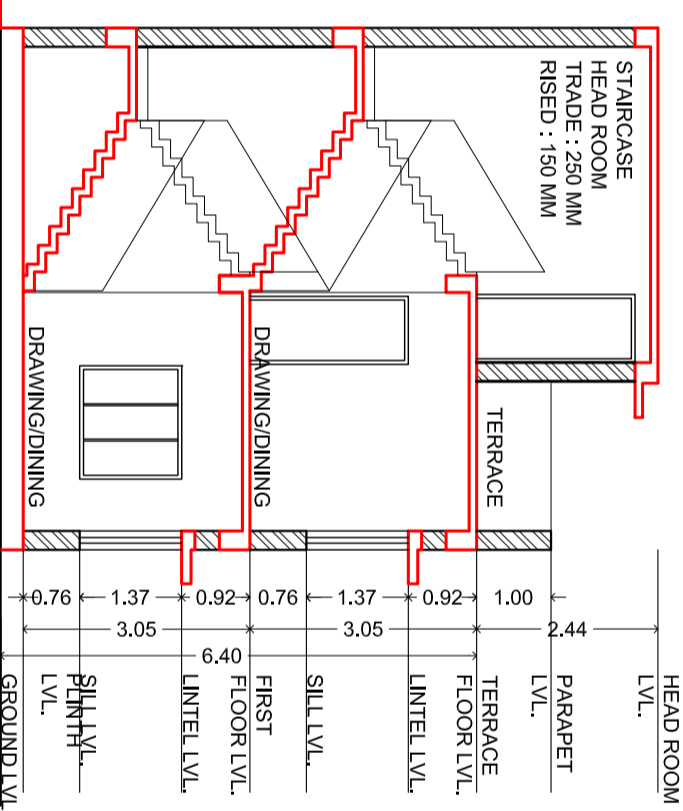

SECTION AT X-X

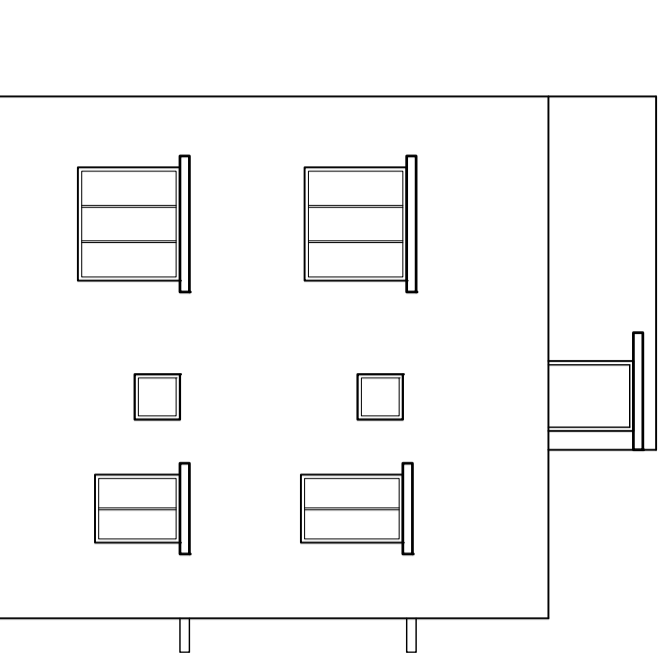

REAR ELEVATION

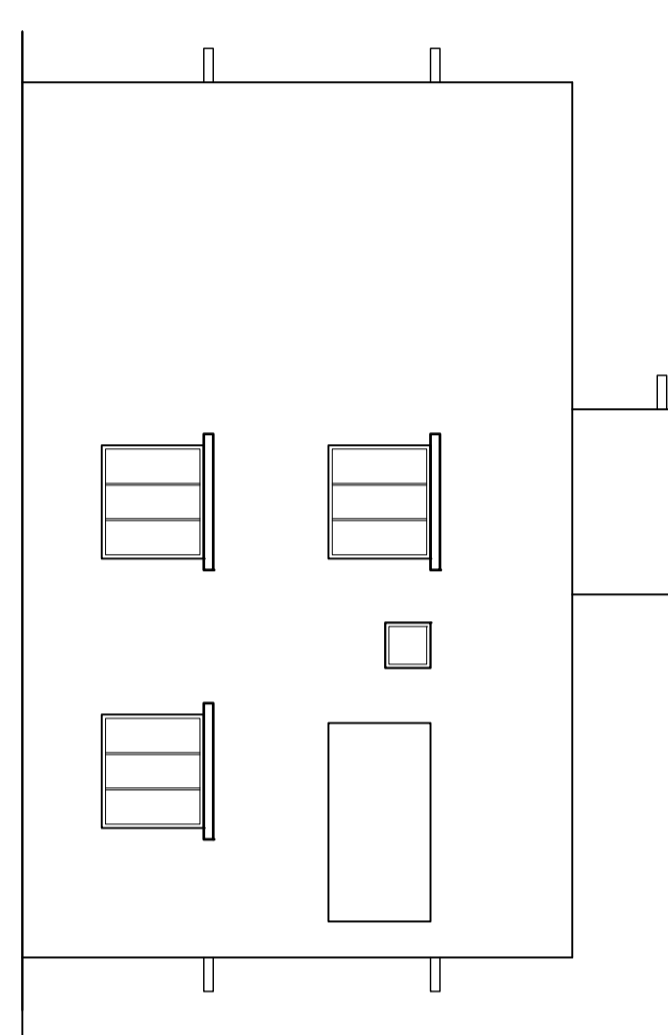

LEFT SIDE ELEVATION

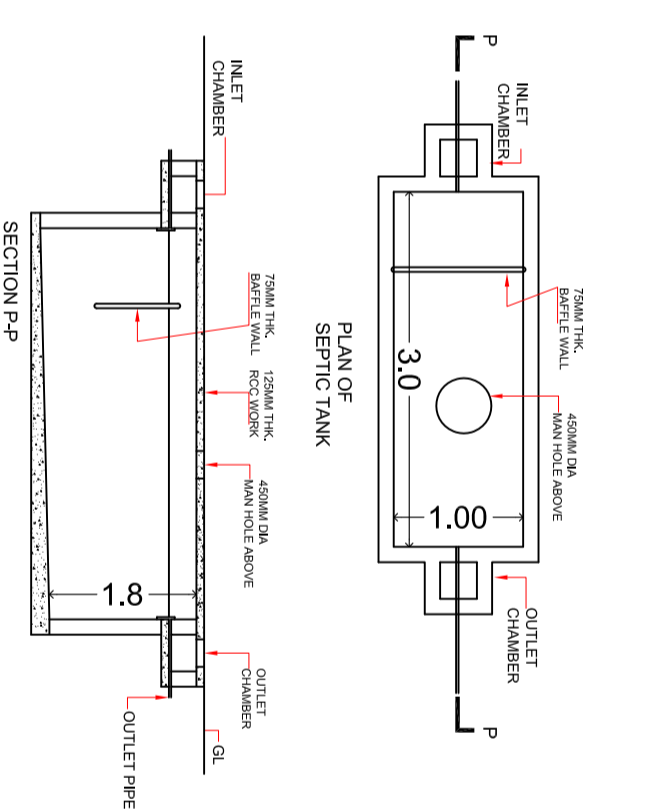

DETAILINGS

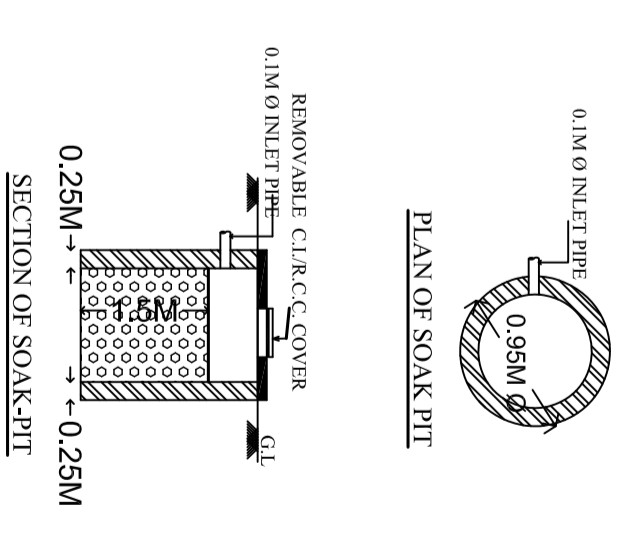

PLAN OF SOAK PIT

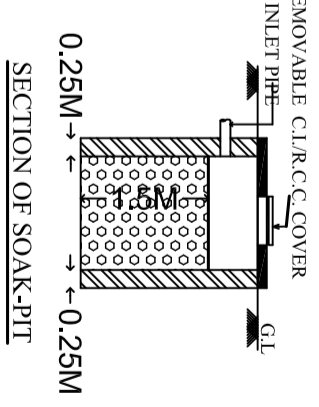

SECTION OF SOAK-PIT

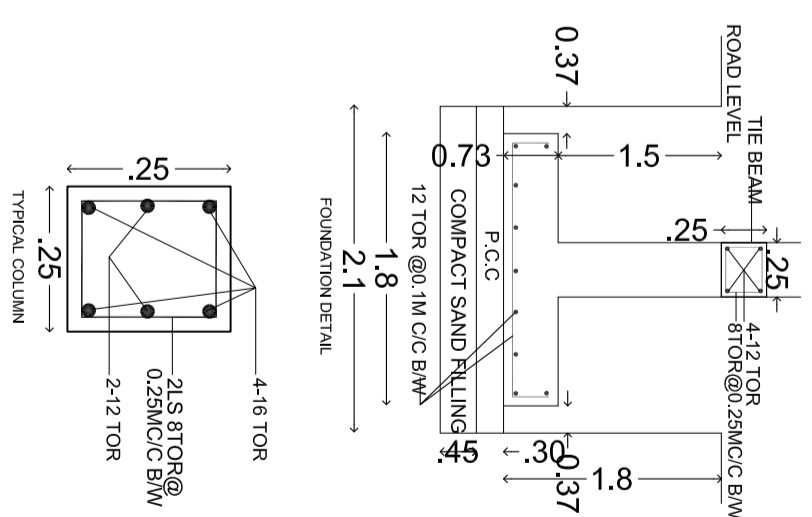

FOUNDATION DETAIL

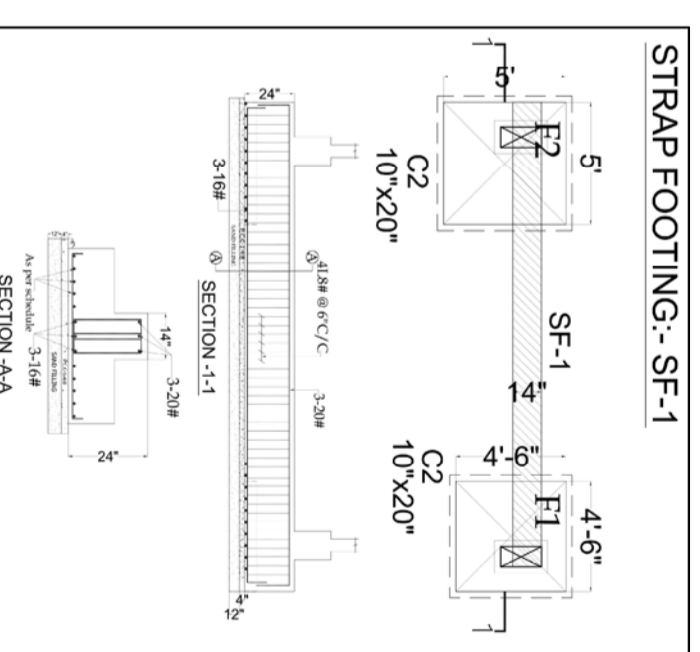

STRAP FOOTING:- SF-1

DRAWING TITLE  
**PROPOSED G+1 STOREIED RESIDENTIAL HOUSE**  
THIS IS A STANDARDIZED PRE-APPROVED PLAN PROVIDED BY

