

SANCTION TEXT

APPROVING AUTHORITY DIGITAL SIGNATURE

DOOR & WINDOW SCHEDULE

SL. NO.	TYPE	SIZE	DESCRIPTION
1	D	1.07 X 2.13	PANELLED DOOR
2	D1	0.91 X 2.13	PANELLED DOOR
3	D2	0.76 X 2.13	PANELLED DOOR
4	W	1.52 X 1.37	MS. GLAZED WINDOW
5	W1	0.91 X 1.37	MS. GLAZED WINDOW
6	W2	1.22 X 1.14	MS. GLAZED WINDOW
7	V	0.61 X 0.61	MS. GLAZED VENTILATOR

AREA AND BUILDING PARAMETERS

PLOT DIMENSIONS (IN FEET)	25' x 50'
PLOT DIMENSIONS (IN MT)	7.62 M x 15.24M
PLOT AREA	116.13 SQMT
GROUND FLOOR BUILT UP AREA	82.48 SQMT
FIRST FLOOR BUILT UP AREA	82.48 SQMT
TOTAL BUILT UP AREA	164.96 SQMT
FLOOR AREA RATIO (FAR)	1.42
BUILDING HEIGHT	6.40 MT
PLANTATION AREA	11.67 SQMT
NUMBER OF TREES PROVIDED	02 NOS

APPLICANT DETAILS

NAME OF APPLICANT	
ADDRESS	
CONTACT NUMBER	

LAND DETAILS

REVENUE VILLAGE	
REVENUE PLOT NO	
SCHEME PLOT NO/ LAYOUT PLOT NO/ SUB PLOT NO	
KHATA NUMBER	

SITE PLAN

DRAWING TITLE  
**PROPOSED G+1 STORIED RESIDENTIAL HOUSE**

THIS IS A STANDARDIZED PRE-APPROVED PLAN IS PROVIDED BY



PRINT ON A2 SIZE PAPER

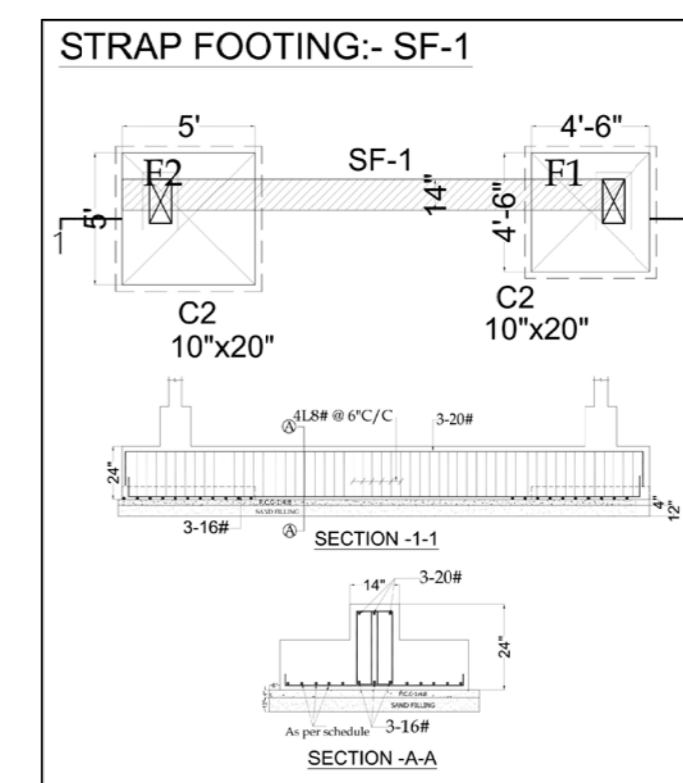
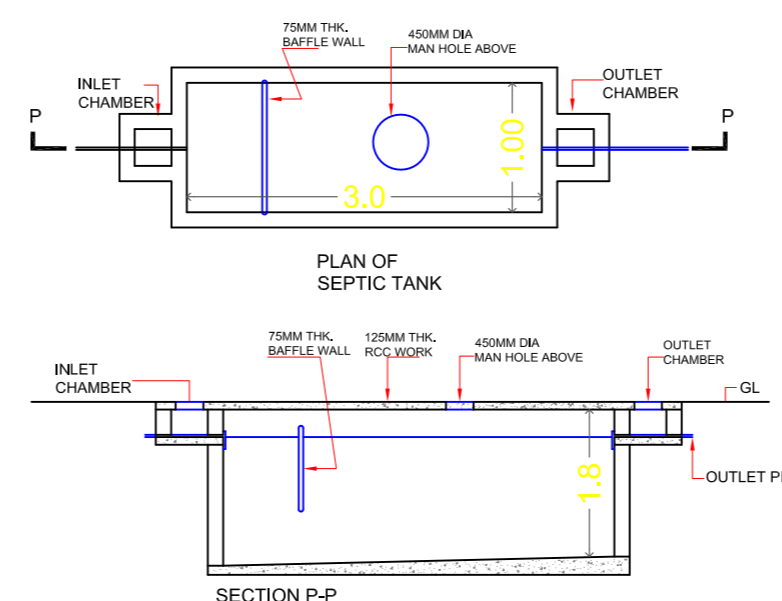
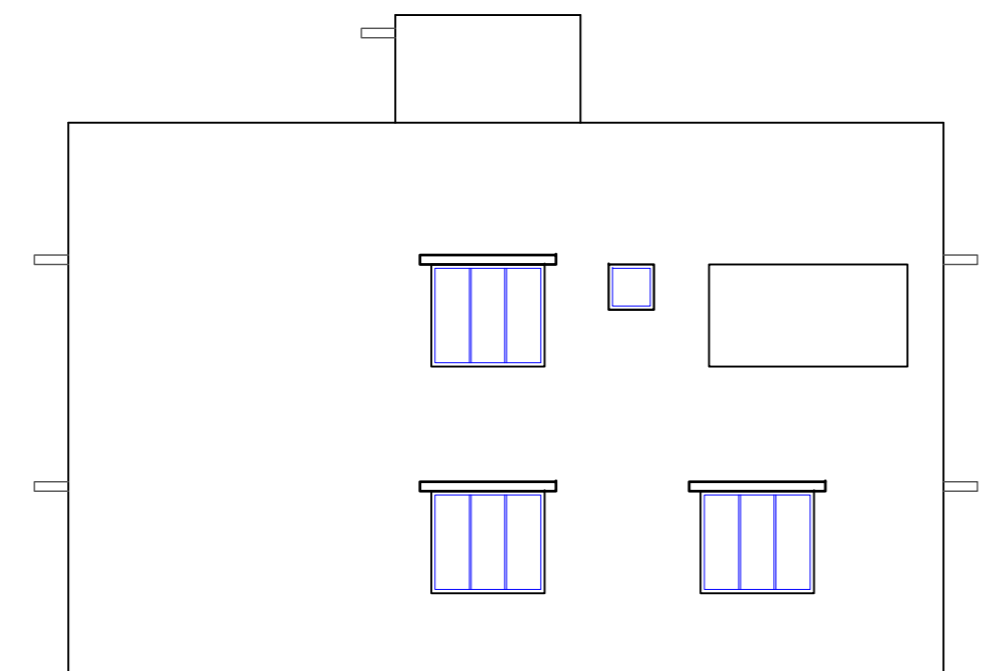
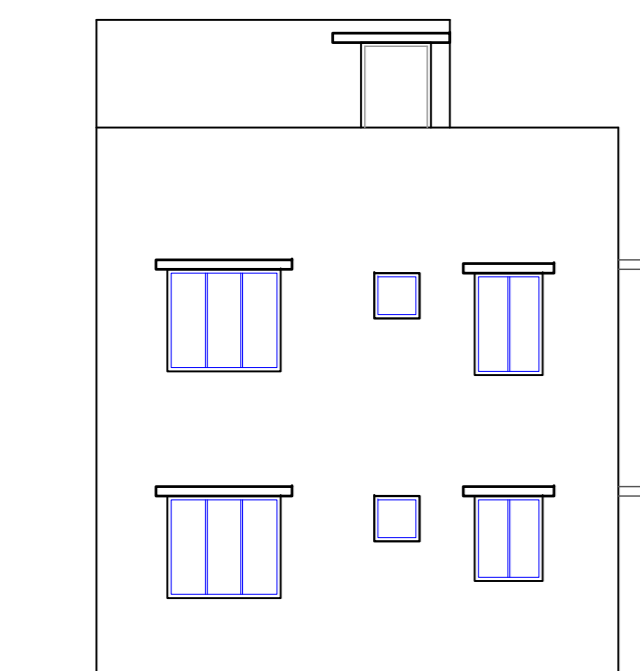
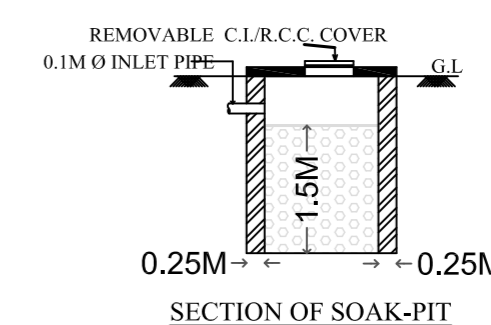
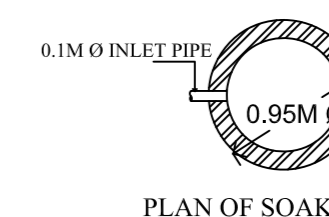
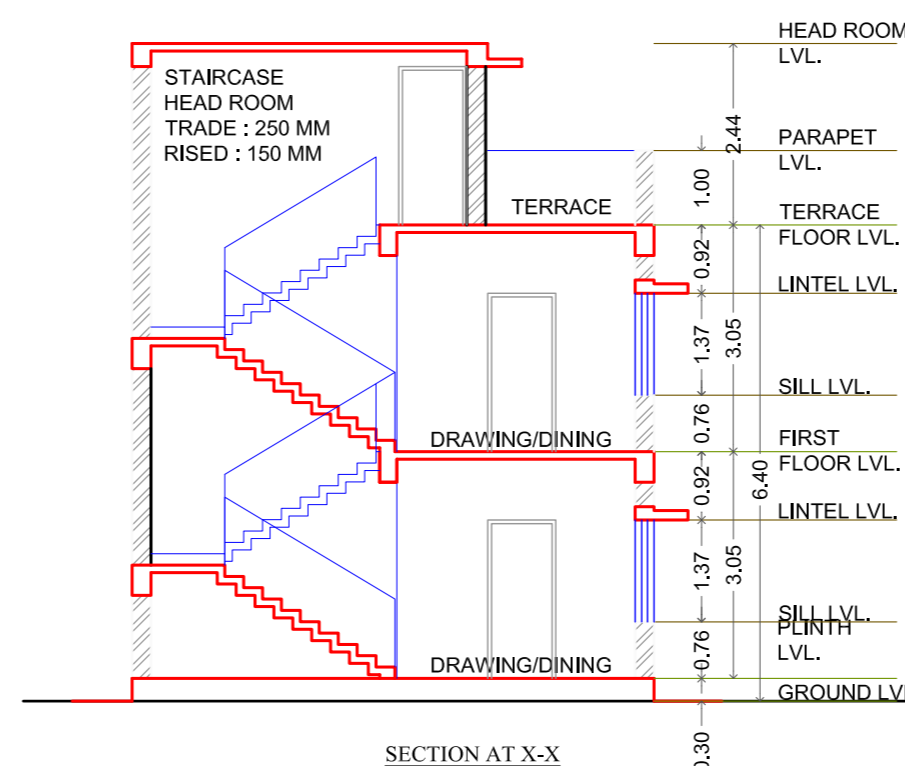
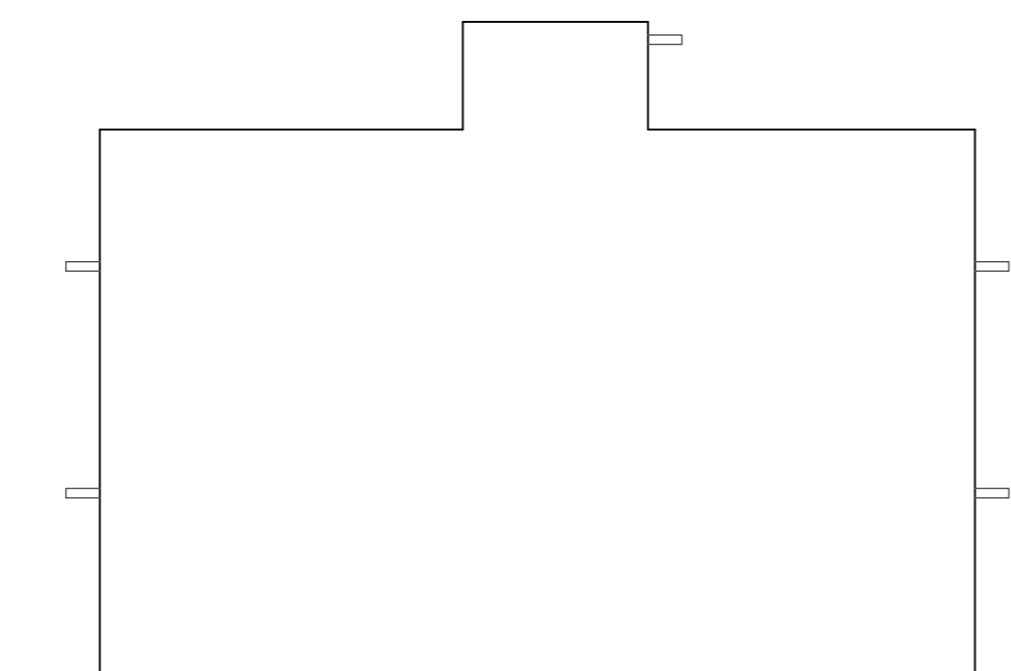
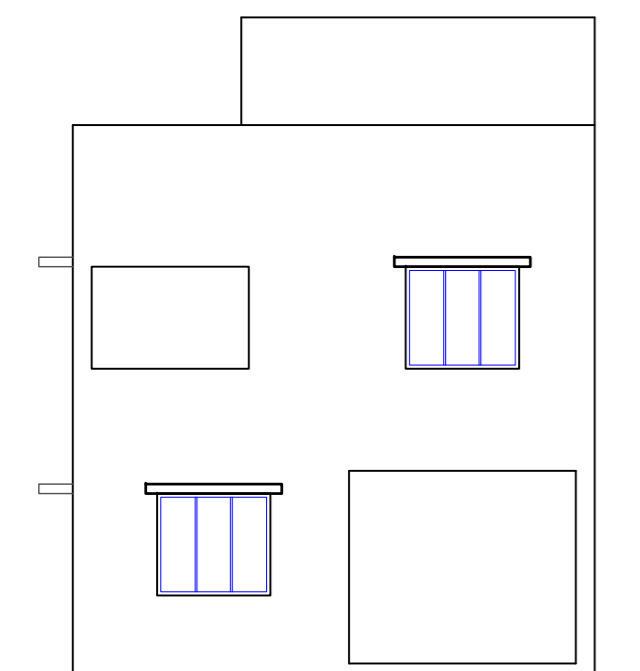
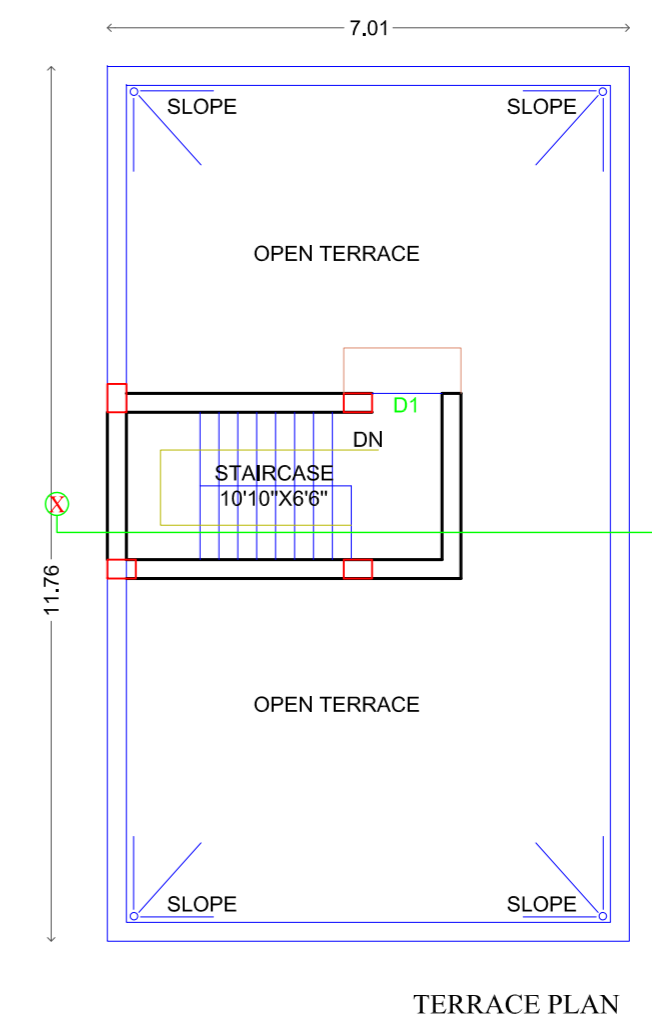
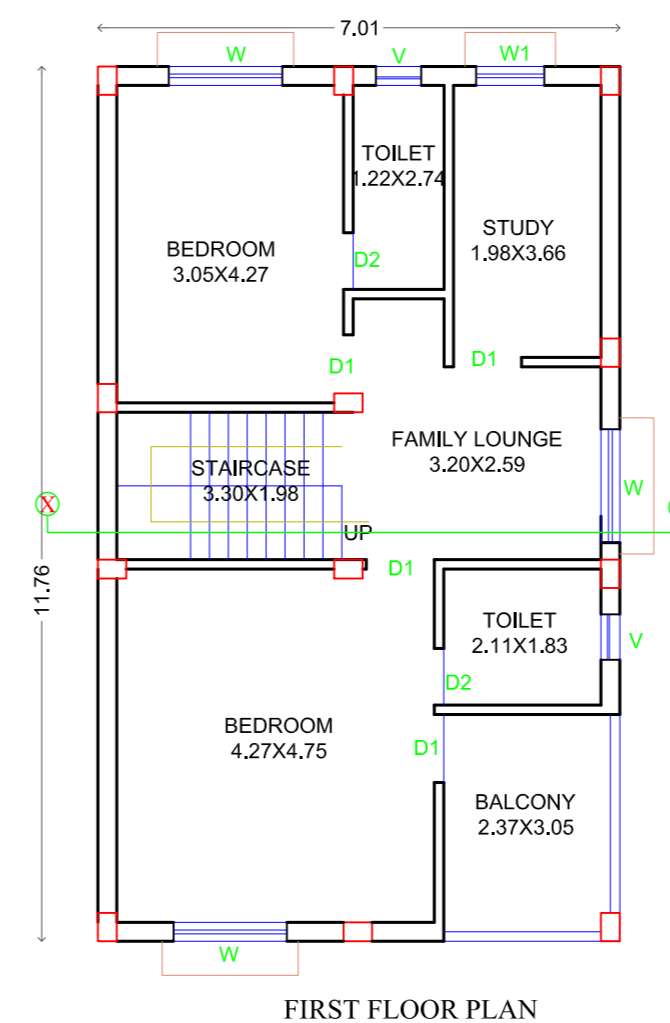
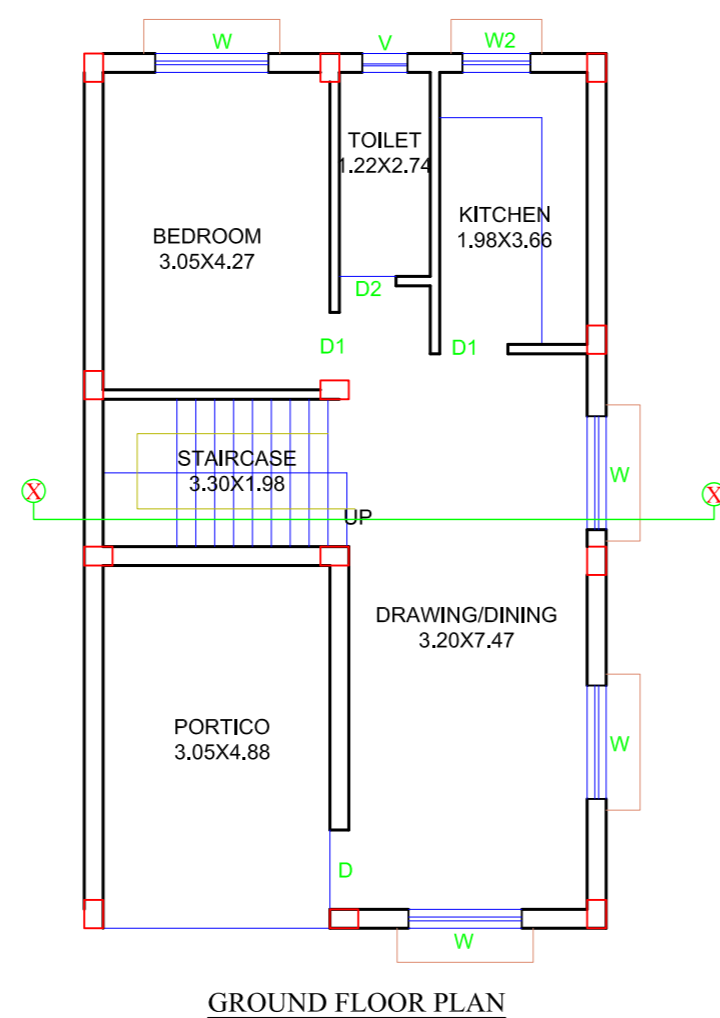
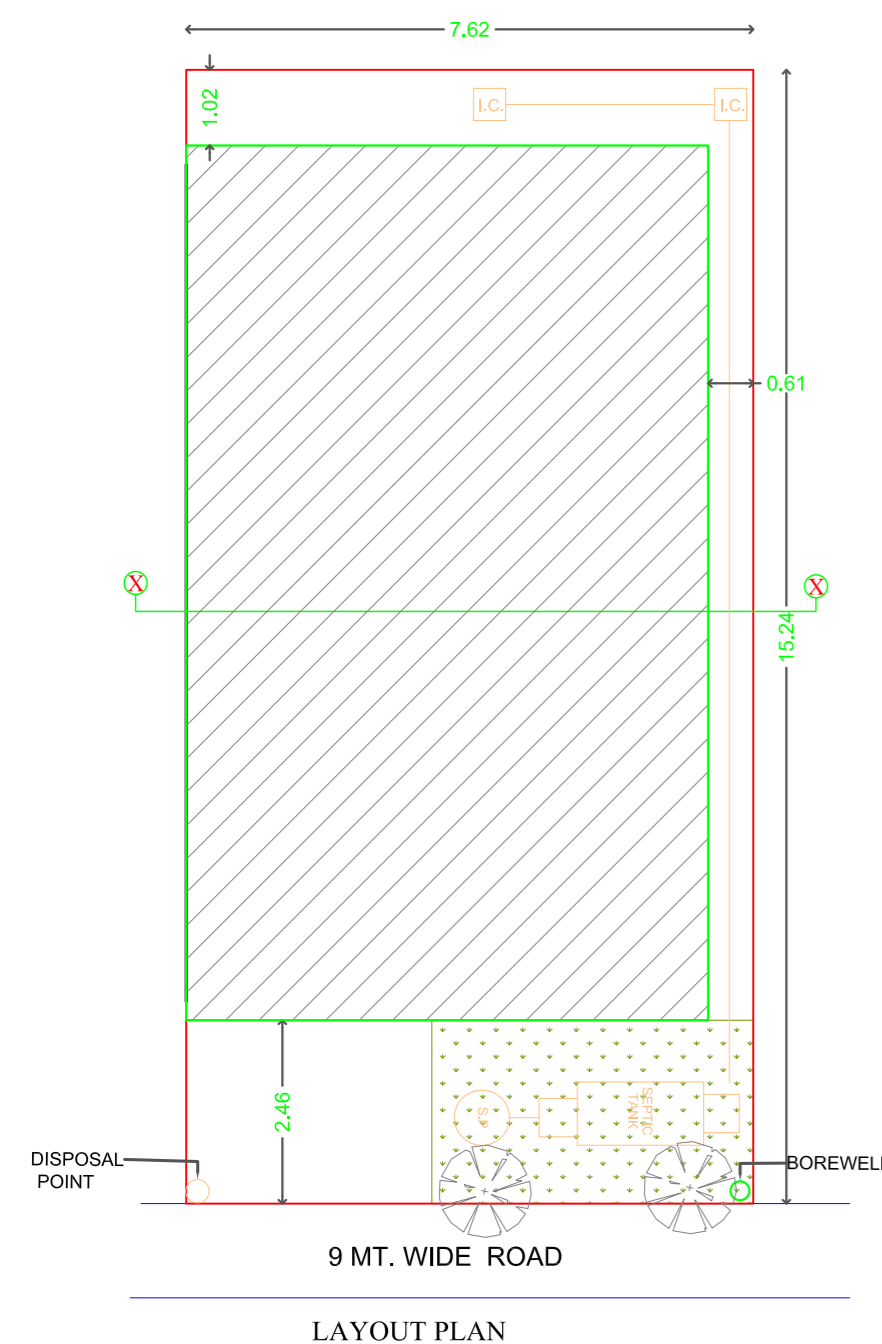

DETAILINGS